

OFERTAS OTOÑO - INVIERNO 2021 - 2022



EG-CIPBAT001

Resolución 1080p. IP65.
Detector de movimiento
Grabación en tarjeta.
Visión nocturna y audio
bidireccional. Batería
recargable 9000 mAh.
Soporte imantado.

Conectable
a la nube



Compatible con:



amazon alexa

84,95€



SCAN ME

CA-PRO80SILENT

3 HP - 8 Bar - 350 Lt/min
1.200 r.p.m. - Sin aceite - 80 Lt.

68 dB
Silencioso



455€



SCAN ME

CE-PROMIG 215

220 A.
Ø electrodo 1,6-4 mm.
Ø hilo max 1,0 mm.
Bobina max 15Kg. (200 mm.)
20 Kg.

MIG/MAG
TIG - DC - LIFT



799€



SCAN ME

PP90 SKID HEA EXTRA

Tamaño boquilla: 0,019"
Flujo max.: 1,9 lt./min.
0,8 Kw.
WG-2414079
Adicional:
WG-2400214
WG-2400216

Pinturas plásticas

Esmaltes, lacas y barnices

SUCCIÓN
DIRECTA DEL
RECIPIENTE

HEA HIGH EFFICIENCY
AIRLESS



1.069€



SCAN ME

Profesionales trabajando para Profesionales

CA-PRO6SILENT

1 HP - 8 Bar
110 Lt/min
1.400 r.p.m.
Sin aceite
6 Lt.

62 dB
Silencioso



139,95€

CA-CS6PROKIT

0,75 HP
8 Bar
105 Lt/min
1.700 r.p.m.
Sin aceite
6 Lt.

59 dB
Silencioso



169€

CA-PRO12SILENT

1 HP - 8 Bar
115 Lt/min
1.400 r.p.m.
Sin aceite
12 Lt.

62 dB
Silencioso



135€

CA-PRO25SILENC

1,5 HP - 8 Bar
150 Lt/min
1.400 r.p.m.
Sin aceite
24 Lt.

59 dB
Silencioso



149€

CA-PRO50SILENC

1,5 HP - 8 Bar
150 Lt/min
1.400 r.p.m.
Sin aceite
50 Lt.

59 dB
Silencioso



189€

CA-PRO40SILENC

2 HP - 8 Bar
196 Lt/min
1.200 r.p.m.
Sin aceite
40 Lt.

65 dB
Silencioso



244€

CA-PRO50SVT

Compresor
150 Lt/min.
115 PSI - 8 BAR
1,5 HP
1.400 r.p.m.
Sin aceite
50 Lt.

59 dB
Silencioso



195€

CA-C330/03PRO

3 HP - 10 Bar
330 Lt/min
1.400 r.p.m.
3 Lt.

Trabajo continuo



789€

CA-POWER AIR

Inflador (550 W)
Soplador (380 W - 720 Lt/min)
16 V - Display digital
5 boquillas.

Bateria



59€

CA-AIR230/12

230/12 V. - 7 Bar
20 Lt/min



39€

CA-TORBELLINO

0.25 HP
3.2 Bar
60 Lt/min

Membrana



95€

CA-PRO7N

230 V. - 1,5 HP
8 Bar - 160 Lt/min
1.400 r.p.m.
Sin aceite
6 Lt.

Asa de transporte



109€

CA-PRO25 / CA-PRO55

230 V. - 2 HP
8 Bar - 195 Lt/min
25 Lt./50 Lt.



CA-PRO25

119€

CA-PRO55

149€

CA-PRO24XT

230 V. - 2,5 HP
8 Bar - 205 Lt/min
24 Lt.



142€

3

CA-PRO50

230 V. - 2,5 HP
8 Bar - 205 Lt/min
50 Lt.



185€

CA-PRO26NG

230 V. - 2,5 HP
9 Bar - 246 Lt/min
Sin aceite
24 Lt.

**Sin mantenimiento
Motor inducción**



142€

CA-PRO51NG

230 V. - 2,5 HP
9 Bar - 246 Lt/min
Sin aceite
50 Lt.

**Sin mantenimiento
Motor inducción**



185€

CA-PRO25VX

230 V. - 3 HP
8 Bar - 340 Lt/min
25 Lt.

Cabezal
en "V"



233€

CA-PRO50VX

230 V. - 3 HP
8 Bar - 340 Lt/min
50 Lt.

Cabezal
en "V"



235€

CA-PRO100VX

230 V. - 3 HP
8 Bar - 340 Lt/min
100 Lt.

Cabezal
en "V"



399€

CA-AB25/3M

230 V. - 3 HP
10 Bar - 330 Lt/min
24 Lt.



469€

CA-AB25/3MGT

230 V. - 3 HP
10 Bar - 330 Lt/min
24 Lt.

Especial
gotelé



599€

CA-AB25/415MGT

230 V. - 3 HP
10 Bar - 400 Lt/min
24 Lt.

TOP
LINE



750€

CA-AB50/3M

230 V. - 3 HP
10 Bar - 330 Lt/min
50 Lt.



475€

CA-AB100/3M

230 V. - 3 HP
10 Bar - 330 Lt/min
100 Lt.



479€

CA-AB100/3T

400 V. - 3 HP
10 Bar - 330 Lt/min
100 Lt.



525€

CA-AB100- 515M
230 V. - 4 HP
10 Bar - 510 Lt/min
100 Lt.

**TOP
LINE**



799€

CA-AB200/3M
230 V. - 3 HP
10 Bar - 330 Lt/min
200 Lt.



619€

CA-AB200/3T
400 V. - 3 HP
10 Bar - 330 Lt/min
200 Lt.



673€

CA-AB200/515M
230 V. - 4 HP
10 Bar - 510 Lt/min
200 Lt.

**TOP
LINE**



969€

CA-AB200/515
380 V. - 4 HP
10 Bar - 510 Lt/min
200 Lt.



969€

CA-AB300/525TF
380 V. - 5,5 HP
11 Bar - 550 Lt/min
270 Lt.



1.099€

CA-AB300-598
380 V. - 5,5 HP
11 Bar - 600 Lt/min
270 Lt.

**TOP
LINE**



1.369€

CA-AB500/7.5T
380 V. - 7,5 HP
11 Bar - 830 Lt/min
500 Lt.



1.599€

CA-AB500/10T
380 V. - 10 HP
11 Bar
1.070 Lt/min
500 Lt.

**TOP
LINE**

Estrella
triángulo



2.499€

CA-AB500/10
380 V. - 10 HP
11 Bar
1070 Lt/min
500 Lt.



2.152€

CA-S1520
5 HP - 10 Bar
275 Lt/min
76 dB
20 Lt.



1.079€

Motor gasolina



CA-AGRI65
5,5 HP - 10 Bar
540 Lt/min
76 dB
11+11 Lt.



2.299€

Motor gasolina



CA-AGRI90/678
9 HP - 10 Bar
670 Lt/min
76 dB
17+17 Lt.

Motor gasolina



2.499€

CA-AGRI90-998
9 HP - 10 Bar
1.090 Lt/min
76 dB
17+17 Lt.

Motor gasolina



3.299€

CA-AGRI75 DIESEL
7,7 HP - 10 Bar
650 Lt/min
76 dB
17+17 Lt.

Motor diesel



3.699€

6

CA-ABT500-1716
380 V. - 7,5 + 7,5 HP
11 Bar
1.776 Lt/min
500 Lt.

BAJO PEDIDO



3.675€

CA-ABT900-1996
380 V. - 10 + 10 HP
11 Bar
2.140 Lt/min
900 Lt.

BAJO PEDIDO



4.700€

CABEZAS COMPRESORAS

Cabezas compresoras de doble pistón. Bloque de cilindro en hierro fundido.

MODELO	HP	LT/MIN	KG.	OFERTA
CA-AB268	2	250	15	145 €
CA-AB348	3	350	15	155 €
CA-AB360	3	360	15	199 €
CA-1127420217	3	350	15	149 €
CA-AB515	4	510	24	239 €
CA-AB525	5,5	550	24	319 €
CA-AB598	5,5	598	30	399 €
CA-AB808	7,5	800	32	439 €
CA-AB858	7,5	650	35	495 €
CA-AB998	10	1069	38	509 €



MOTORES ELECTRICOS

Motores para compresores de aire con polea.

MODELO	DESCRIPCIÓN	KG.	OFERTA
CA1124150082	230V- 2 HP	17	135 €
CA1124150077	230V- 3 HP	19	159 €
CA1124150031	380V- 3 HP	19	209 €
CA1124150018	380V- 4 HP	28	259 €
CA1124150024	380V- 5,5 HP	30	339 €
CA1124150091	380V- 7,5 HP	35	359 €
CA1124150083	380V- 10 HP	40	359 €



CA-ACEITE1LT

Aceite aceite especial para compresores de pistón. 1 Lt. SAE 30/40



Pistón

10 €

CA-ACEITE5LCP46

Aceite aceite especial para compresores de tornillo. 5 Lt. SAE 10/20



Tornillo

7

35 €

CA-ACEITE5LT

Aceite aceite especial para compresores de pistón. 5 Lt. SAE 30/40



Pistón

34 €

CA-901

Tapón de aceite para compresor monoblock. (2 uds.)



9,92 €



NE-RP7225

Atornillador recto

- 11.000 r.p.m.
- 2 HP (*)
- 74 Lt/min
- 45 Nm.
- Portapuntas de 3 a 5 mm.



39 €

NE-RP17113

Taladro recto

- 2.300 r.p.m.
- 2 HP (*)
- 114 Lt/min



45 €

10 mm.

NE-RP17102

Taladro

- 1.800 r.p.m.
- 2 HP (*)
- 114 Lt/min



56 €

10 mm.

NE-RP17108

Taladro

- 700 r.p.m.
- 2 HP (*)
- 114 Lt/min



67 €

13 mm.

NE-RP17407

Llave impacto

- 7.500 r.p.m.
- 3 HP (*)
- 183,9 Lt/min
- 610 Nm



78 €

1/2"

NE-RP7426

Llave impacto

- 8.500 r.p.m.
- 3 HP (*)
- 610 Nm.



109,20 €

1/2" Mini

NE-RP7462

Llave impacto

- 4.600 r.p.m.
- 3 HP (*)
- 183,9 Lt/min
- 1800 Nm



199 €

3/4"

NE-RP7488

Llave impacto

- 3.600 r.p.m.
- 5 HP (*)
- 295 Lt/min
- 3100 Nm



277 €

1"

NE-RP17411

Llave de carraca

- 160 r.p.m.
- 2 HP (*)
- 114 Lt/min
- 67,5 Nm



56 €

1/2"

NE-RP17314

- Miniamoladora
 • 22.000 r.p.m
 • 1,5 HP (*)
 • 126,2 Lt/min



39€

NE-RP17610

- Cizalla
 • 1.800 r.p.m
 • 2 HP (*)
 • 114 Lt/min
 • Capacidad de corte max.: 1.6 mm



67€

NE-RP8043

- Pistola de grasa
 • 3,5/6 cfm
 • 90 PSI - 4 BAR
 • 400 c.c



37€

NE-RP17621

- Cincelador
 • 79,2 Lt/min
 • 4.500 golpes minuto.



33€

NE-RP7336S

- Lijadora orbital
 • 12.000 r.p.m
 • 2 HP (*)
 • 128 Lt/min
 • Plato de goma 150 mm
 • Plato lija 6 "



94€

NE-RP7636

- Multifunción
 • 128 Lt/min
 • 6,3 Bar
 • 16.000 osc/min.



66€

9

NE-RP7006

- Juego de llaves de vaso 1/2"
 11-12-13-14-16-17-19-21-22. 24 mm.
 Para modelo:
 NE-RP7336S
 NE-RP7426



18€

NE-RP7002

- Kit cinceles. Para modelo: NE-RP17621



12€

NE-RP7001

- Muelle
 Para modelo:
 NE-RP17621



6€

NE-RP7636-1

- Kit multiusos
 Para modelo:
 NE-RP7636



20€

NE-RP7336S-1

- Plato goma 150 mm
 Para modelo:
 NE-RP7336S



6€

NE-RP7336S-2

- Pack 10 lijas GR80.
 Para mod.: NE-RP7336S5

NE-RP7336S-3

- Pack 10 lijas GR120.
 Para mod.: NE-RP7336S5

NE-RP7336S-4

- Pack 10 lijas GR180.
 Para mod.: NE-RP7336S5



PACK 5€

NE-KN580

Kit neumático:
Llave impacto,
llave carraca,
martillo,
mini esmeril + accesorios

34 pzs

89 €



NE-KN11

Mini amoladora con cuerpo
de aluminio fundido. 6.3 Bar



37 €

NE-KN16

Kit pistola de impacto.
6 Bar
310 Nm

16 pzs



55 €

NE-KN6BLIS

Kit martillo
cincelador.
6 Bar
450 golpes/min



34 €



NE-KN8

Atornillador neumático.
6 Bar
800 r.p.m.

Par de
apriete
regulable



175 €

NE-KN18

Atornillador neumático.
6 Bar
1800 r.p.m.



88 €

NE-KN10BLIS

Taladro neumático
Cuerpo aluminio fundido.
6 Bar.
Portabrocas automático
reversible: 6 mm.



40 €

NE-KN6615K

Remachadora.
6.3 Bar
7.063 Nm



109 €

R16/64K

Clavadora 4 - 7 Bar
Clavo 14 de 32 a 64 mm.



121€

R64KC

Clavadora 8 Bar
Clavo "T" hierro y acero de 18 a 64 mm.



121€

R16/50 KOMBI

Clavadora 5,2-7,6 Bar
Clavo 14 de 20 a 50 mm.
Clavo Mini T de 18 a 50 mm.



121€

R6/35

Clavadora 4 - 7 Bar
Pin y Minibrad 0,6 de 12 a 35 mm.



120€

R8/40

Clavadora 4 - 7 Bar
Pin y Minibrad 0,8 de 12 a 40 mm.



129€

R18/51

Clavadora 4 - 7 Bar. Clavo de 12 de 15 a 50 mm.



95€

R80/16

Grapadora 4 - 7 Bar
Grapa 80 de 6 a 16 mm.



39€

MCCF15PK

Grapadora 4.5-8 Bar
Chapa corrugada de 9 a 15 mm.



309€

R18/30

Clavadora 4-7 Bar
Clavo 12 de 10 a 32 mm.



45€

R12/51D

Clavadora 4 - 7 Bar
Brad 12 de 15 a 50 mm.



39€

SF50/40

Grapadora / Clavadora 4 - 7 Bar
Brad 12 de 12 a 50 mm.
Grapa 90 de 16 a 40 mm.



39€

PIN 0,8 SIN CABEZA

Blister
2.000 uds.

REFERENCIA	LARGO (mm.)	OFERTA BLISTER
MCPINO.8-20BLIS	20	3,47 €
MCPINO.8-30BLIS	30	4,13 €

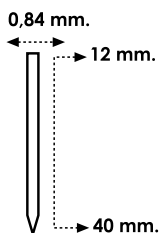

PIN 0,8 CON CABEZA

Blister
2.000 uds.

REFERENCIA	LARGO (mm.)	OFERTA BLISTER
MINIBRAD820BLIS	20	3,47 €
MINIBRAD830BLIS	30	4,13 €

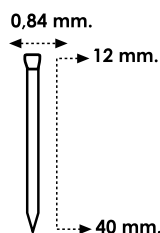

BRAD 12

Blister
1.000 uds.

REF.	LARGO (mm.)	OFERTA BLISTER
MCBRAD12-20BLIS	20	2,31 €
MCBRAD12-30BLIS	30	2,31 €
MCBRAD12-40BLIS	40	4,13 €
MCBRAD12-50BLIS	50	4,13 €

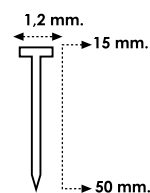

BRAD 14

Blister
1.000 uds.

REFERENCIA	LARGO (mm.)	OFERTA BLISTER
MCBRAD14-30BLIS	30	3,47 €
MCBRAD14-40BLIS	40	4,13 €

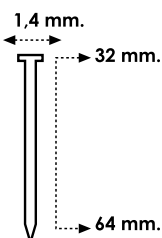

CLAVO MINI T ACERO

Blister
500 uds.

REFERENCIA	LARGO (mm.)	OFERTA BLISTER
MCMINIT-18BLIS	18	7,15 €
MCMINIT-30BLIS	30	7,70 €
MCMINIT-40BLIS	40	8,80 €

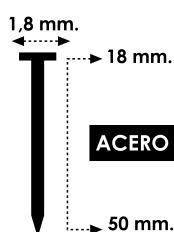

GRAPA 80

Blister
1.000 uds.

REFERENCIA	LARGO (mm.)	OFERTA BLISTER
MCGRAPA80-8BLIS	8	2,31 €
MCGRAPA80-12BLI	12	2,31 €
MCGRAPA80-16BLI	16	3,03 €

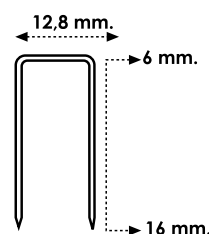

GRAPA 90

Blister
1.000 uds.

REFERENCIA	LARGO (mm.)	OFERTA BLISTER
MCGR90-20BLIS	20	3,03 €
MCGR90-25BLIS	25	3,63 €
MCGR90-30BLIS	30	3,63 €

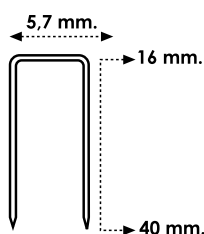

CA-1852

Pistola de pintar.
Cuerpo de aluminio.
Conexión rápida.
Abanico 110 - 220 mm.
Apta para boquillas de \varnothing 1,5 mm.

Semi-profesional
600 cc.



22 €

CA-1850

Pistola de pintar.
Cuerpo de aluminio.
Conexión rápida.
Abanico 119 - 220 mm.
Apta para boquillas de \varnothing 1,5 mm.

Semi-profesional
750 cc.



22 €

CA-1851

Pistola de pintar Mini. 3-4 Bar
90-150 Lt/min
Apta para boquillas de \varnothing 0,5 - 1,8 mm.

125 cc.



28 €

CA-1856/3-1.4

Pistola de pintar
3-6 Bar
170-320 Lt/min
Apta para boquillas (1.4, 1.7, 2.0)
Boquilla de serie de \varnothing 1.4 mm.

600 cc.
Lacas
Barnices



34 €

CA-1856/3

Pistola de pintar
3-6 Bar
170-320 Lt/min
Apta para boquillas (1.4, 1.7, 2.0)
Boquilla de serie de \varnothing 1.7 mm.

600 cc.
Esmaltes



34 €

CA-1856/3-2.0

Pistola de pintar
3-6 Bar
170-320 Lt/min
Apta para boquillas (1.4, 1.7, 2.0)
Boquilla de serie de \varnothing 2.0 mm.

600 cc.
Aparejo e
Imprimaciones



34 €

CA-1855/3L

Pistola de pintar
3-6 Bar
110-180 Lt/min
Apta para boquillas de \varnothing 1.4 - 2.0 mm.
Boquilla de serie de \varnothing 1.7 mm.

1.000 cc.



34 €

CA-1805

Pistola de pintar por gravedad. 1,75 Bar
200 Lt/min.
3 boquillas incluidas

6.000 cc.
Gotelé



33 €

CA-1806L

Pistola de pintar por gravedad. 3-6 Bar
275 Lt/min
Boquilla de serie \varnothing 1 mm.

5.000 cc.
Lisos



99 €

CA-1857 1.3

Pistola de pintar por gravedad profesional.
2-2.5 Bar
160-220 Lt/min
600 ml. Boquilla de serie 1.3 mm. Altura de pulverización. 19-30 cm.

Carrocería



79 €

CA-1857 1.4

Pistola de pintar por gravedad profesional.
2-2.5 Bar
160-220 Lt/min
600 ml. Boquilla de serie 1.4 mm. Altura de pulverización. 19-30 cm.

Lacas, barnices



79 €

CA-1857 1.7

Pistola de pintar por gravedad profesional.
2-2.5 Bar
160-220 Lt/min
600 ml. Boquilla de serie 1.7mm. Altura de pulverización. 19-30 cm.

Esmaltes



79 €

CA-1857 2.0

Pistola de pintar por gravedad profesional.
2-2.5 Bar
160-220 Lt/min
600 ml. Boquilla de serie 2.0 mm. Altura de pulverización. 19-30 cm.

Aparejo, imprimaciones



79 €

CA-1857 2.5

Pistola de pintar por gravedad profesional.
2-2.5 Bar
160-220 Lt/min
600 ml. Boquilla de serie 2.5 mm. Altura de pulverización. 19-30 cm.

Forja, aparejo



79 €

JUEGO DE BOQUILLAS Y AGUJAS

Para CA-1855/3L

Ref.: CA-KIT1.4/1855 (1,4 mm.)
Ref.: CA-KIT2.0/1855 (2.0 mm.)

Para CA-1856/3

Ref.: CA-KIT1.4/1856 (1,4 mm.)
Ref.: CA-KIT2.0/1856 (2,0 mm.)



PACK 18 €

JUEGO DE BOQUILLAS Y AGUJAS

Para CA-1805

Ref.: CA-1805-BOQUILL
Juego 3 boquillas

10 €



Para CA-1806L

Ref.: CA-1806-BOQUILL
Juego 3 boquillas

25 €

CA-1150

Pistola de soplar
Presión máx. 10 bar



4,19 €

CA-1160

Pistola de soplar caña larga
Largo 15 cms.
Presión máx. 10 bar



7,50 €

CA-1400/1

Pistola de petroleo.
750 cc.
4-7 Bar
Conexión rápida

Ø Boquilla 2.0 mm.



13 €

CA-1180/1

Hinchador de neumáticos
0-12 Bar



13 €

CA-60G-T/PSI

Hinchador de neumáticos
0-10 Bar
Latiguillo 1 m.
Ø 63 mm.



52 €

CA-1161/2

Pistola de soplar caña larga y boquilla curva
Presión máx.
10 Bar

Conexión rápida
30 cm.



13 €

CA-1161/3

Pistola de soplar caña larga y boquilla curva
Presión máx.
10 Bar

Conexión rápida
50 cm.



16 €

CA-1161/4

Pistola de soplar caña larga y boquilla curva
Presión máx.
10 Bar

Conexión rápida
80 cm.

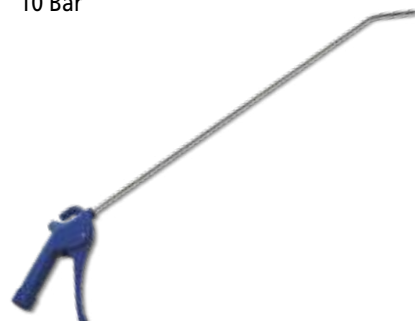

22 €

KN-8040

Pistola de arenar-chorrear.
100 Lt/min
Manguera goma:
3 mt. con
ø12x18 mm.
Boquillas:
ø 0,5 mm. (2 uds.)
ø 6,3 mm. (1 ud.)
Presión máx.
9 Bar.

Precisa compresor
de 250 Lt/min



32 €

CA-1151

Pistola de soplar
Boquilla curva
Entrada aire 1/4"
Presión máx. 10 bar

Conexión rápida



5,50 €

CA-SPR4-6.5

Tubo espiral
"Poliuretano"
ø 6,5 - 10 mm.

5 mt.



11,52 €

15

CA-SPR10-812

Tubo espiral
"Poliuretano"
ø 8 - 12 mm.

10 mt.



23,05 €

CA-SRU5-8

Tubo espiral
"Rilsan"
ø 6 - 8 mm.

5 mt.



7,33 €

CA-SRU10-8

Tubo espiral
"Rilsan"
ø 6 - 8 mm.

10 mt.



10,48 €

CA-AM80-8

Enrollador automático
manguera. ø Interno 8 mm.
Longitud 10 mt.
Presión máx. 15 bar
Racord salida 1/4

Interior
8 mm.
Aire



99 €

CA-AM85-10

Enrollador automático
manguera. ø Interno
10 mm. Longitud 16 mt.
Presión máx. 15 bar
Racord salida 3/8

Interior
10 mm.
Aire



149 €

CA-AM86-13

Enrollador automático
manguera. ø Interno
10 mm.
Longitud 16 mt.
Presión máx. 15 bar
Racord salida 1/2

Interior
12,5 mm.
Aire/Agua



279 €

CA-1815PRO

Enrollador automático
manguera de aire / agua
Metálico.
40 Bar
Conexión 3/8"

Interior
12,5 mm.
15 mt.



119,70 €

CA-1810

Enrollador automático
manguera de aire
Plástico
Conexión 1/4"
10 Bar

10 mt.



54,02 €

CA-4315-GS

Enrollador automático
Longitud manguera 15 mt.
Cable 3G 1,5 H 05 VVF
Incluye enchufe.
Térmico de protección.

Eléctrico



169 €

CA-630

Equilibrador de carga
Longitud cuerda 1,6 mt.
Peso 0,63 Kg.

Carga
0.4-1.0 Kg



29 €

CA-631

Equilibrador de carga
Longitud cuerda 1,6 mt.
Peso 0,67 Kg.

Carga
1.0-2.0 Kg



33 €

CA-633

Equilibrador de carga
Longitud cuerda 2,5 mt.
Peso 2,85 Kg.

Carga
2.0-4.0 Kg



79 €

CA-CK220

Kit aerográfico para compresor 6 pzas.
Pistola de soplar hinchador espiral 5 mt.
3 boquillas.



Conexión rápida

21 €

CA-CK3300

Kit aerográfico para compresor 5 pzas.
Pistola de soplar, petroleo, soplador, inflador espiral 5 mt.



Conexión rápida

32 €

CAKIT8PRO

Kit aerográfico para compresor 8 pzas.
Pistola de pintar, de petroleo, soplador, inflador, espiral 5 mt. 3 boquillas



Conexión rápida

41 €

17

CA-MANGUERA10

Manguera de goma 20 Bar

10 mt.



19,95 €

CA-MANGUERA20

Manguera de goma 20 Bar

20 mt.



31,45 €

CA-MANGUERA50

Manguera de poliuretano 20 Bar

50 mt.



43 €

REDUCTOR MACHO-HEMBRA

REF.	DESCRIPCIÓN	OFERTA
CA-270/1	De 1/8" a 1/4"	2,58 €
CA-270/3	De 1/4" a 3/8"	2,76 €
CA-270/6	De 3/8" a 1/2"	3,65 €
CA-270/9	De 1/2" a 3/4"	4,02 €



CONEXIÓN HEMBRA

REF.	DESCRIPCIÓN	OFERTA
CA-280/5	De 1/4" a 1/4"	4,04 €
CA-280/8	De 3/8" a 3/8"	3,78 €
CA-280/10	De 1/2" a 1/2"	5,51 €



REDUCTOR MACHO-MACHO

REF.	DESCRIPCIÓN	OFERTA
CA-290/2	De 1/8" a 1/4"	2,71 €
CA-290/5	De 1/4" a 1/4"	2,71 €
CA-290/6	De 1/4" a 3/8"	2,93 €
CA-290/8	De 3/8" a 3/8"	2,93 €
CA-290/9	De 3/8" a 1/2"	3,53 €
CA-290/10	De 1/2" a 1/2"	3,53 €



LLAVE DE PASO

REF.	DESCRIPCIÓN	OFERTA
CA-495/1	1/4" H-H	9,87 €
CA-495/2	3/8" H-H	9,92 €
CA-495/3	1/2" H-H	15,44 €
CA-495/4	3/4" H-H	14,89 €



CA-1110

Boquilla válida para neumáticos ø 6mm.



2,10 €

CA-1110/5

Kit de accesorios universales para inflado



3,68 €

18

LLAVE DE PASO

REF.	DESCRIPCIÓN	OFERTA
CA-495/5P	De 1/4" P M-M	6,07 €



CA-466/2

Enchufe rápido universal de seguridad para manguera ø 8 mm.



25,36 €

CA-469

Enchufe rápido universal de seguridad.

CA-469/1 - 1/4"

CA-469/2 - 3/8"

Rosca hembra



25,36 €

CA-470

Enchufe rápido universal de seguridad.

CA-470/1 - 1/4"

CA-470/2 - 3/8"

CA-470/3 - 1/2"

Rosca macho



25,36 €

ENCHUFE RÁPIDO UNIVERSAL

Rosca hembra

REF.	DESCRIPCIÓN	OFERTA
CA-459/1	De 1/4"	4,41 €
CA-459/2	De 3/8"	5,04 €



ENCHUFE RÁPIDO UNIVERSAL CON RACOR PARA MANGUERA

REF.	DESCRIPCIÓN	OFERTA
CA-456/1	Ø 6 mm.	6,62 €
CA-456/2	Ø 8 mm.	4,41 €
CA-456/3	Ø 10 mm.	5,41 €



ENCHUFE RÁPIDO UNIVERSAL

Rosca macho

REF.	DESCRIPCIÓN	OFERTA
CA-460/1	De 1/4"	4,41 €
CA-460/2	De 3/8"	5,29 €
CA-460/3	De 1/2"	5,51 €



CONEXIÓN RÁPIDA PARA MANGUERA

REF.	DESCRIPCIÓN	OFERTA
CA-445/3	Ø 6 mm.	1,93 €
CA-445/4	Ø 8 mm.	1,66 €



CONEXIÓN RÁPIDA

Rosca hembra

REF.	DESCRIPCIÓN	OFERTA
CA-449/2	De 1/4"	1,66 €
CA-449/7	De 3/8"	2,87 €



CONEXIÓN RÁPIDA

Rosca macho

REF.	DESCRIPCIÓN	OFERTA
CA-450/2	De 1/4"	1,66 €
CA-450/7	De 3/8"	2,85 €



GRIFO PURGADOR

REF.	DESCRIPCIÓN	OFERTA
CA-490/1	De 1/4"	3,42 €
CA-490/2	De 3/8"	3,86 €



VÁLVULA DE SEGURIDAD

REF.	BAR	DESCRIPCIÓN	OFERTA
CA-565/4	11	De 3/8"	7,72 €
CA-565/1	8,8	De 1/4"	4,41 €



RACOR EN "L"

REF.	DESCRIPCIÓN	OFERTA
CA-260/1	1/8" - 1/8"	3,48 €
CA-260/2	1/4" - 1/4"	3,64 €
CA-260/3	3/8" - 3/8"	3,75 €



CA-485

Racor 3 vías, 2 hembras y 1 macho. 1/4" - 1/4"



4,19 €

NE-KN8055

Mini lubricador 1/4"



4,97 €

CA-49A

Doble tuerca fresada 1/4" - 1/4"



3,31 €

CA-874

Filtro de aire cuello largo. 3/8"



6,07 €

CA-875/5

Filtro plástico profesional para compresores. 3/8 - 1/2"



6,07 €

CA-875/6

Filtro metálico profesional para compresores. 1/4"

Con silenciador



8,27€

CA-875/8

Filtro metálico profesional para compresores. 1/2"



8,27€

CA-PRO25VX-27

Filtro de plástico profesional para compresores. 3/8"



8,27€

CA-740

Rosca inferior. Ø 63 mm. 1/4 ". 12 bar



CA-760

Rosca trasera. Ø 63 mm. 1/4 ". 12 bar

9,45€

CA-780

Rosca trasera. Ø 50 mm. 1/4 ". 12 bar



CA-790

Rosca trasera. Ø 40 mm. 1/8 ". 12 bar

7,35€

CA-970PRO

Regulador de presión con manómetro



13,65€

CA-950/1

Regulador de presión con manómetro y 2 enchufes rápidos. 180 Lt./min. 3/8" 0 - 12 bar. Conexión macho.



29,77€

CA-950/2

Regulador de presión con manómetro y 2 enchufes rápidos. 180 Lt./min. 1/2" 0 - 16 bar. Conexión macho.



39,69€

CA-924

Grupo filtro reductor lubricador 240 Lt./min. 1/4" 0-12 bar 8,4 C.M.F. 14,4 m³/h



59,54€

CA-930/12

Grupo filtro reductor lubricador 450 Lt./min. 3/8" y 1/2" 0-12 bar 15,8 C.M.F. 27 m³/h.



82€

CA-922

Regulador de presión con manómetro y filtro 240 Lt./min. 1/4" 0-12 bar 8,4 C.M.F. 14,4 m³/h



26,46€

CA-940/12

Regulador de presión con manómetro y filtro 450 Lt./min. 3/8" y 1/2" 0-12 bar 15,8 C.M.F. 27 m³/h.



50,72€

CA-920

Filtro purificador
Conexión
hembra 1/4"



23,15 €

CA-919/12

Filtro purificador
Conexión
hembra 3/8"
y 1/2"



40,79 €

CA-871/1

Presostato con válvula
de arranque.
8 bar.
Potencia: 2 HP
monofásico.



Conexión
rápida

17,09 €

CA-871/2

Presostato con válvula
de arranque.
8 bar. Monofásico
con rosca para
Huracán, Tornado,
Tifón, Pro6,
Pro 24, Pro 50.



12,60 €

CA-840/1

Presostato sin válvula
de arranque.
10 bar.
Potencia: de
2 HP a 3 HP.
3-6 AMP.



67,25 €

CA-840/2

Presostato sin válvula
de arranque.
10 bar.
Potencia: de
3-5,5 HP.
6-10 AMP.



69,46 €

CA-840/3

Presostato sin válvula
de arranque.
10 bar. Potencia:
de 4HP a 7,5 HP.
10-16 AMP.



69,46 €

CA-921

Lubricador de aceite
42 cc.
Conexión hembra
1/4" - 1/4"
0-12 bar



25,36 €

CA-929/12

Lubricador de aceite
68 cc.
Conexión hembra
3/8" y 1/2"
0-12 bar



39,69 €

VÁLVULA ANTI-RETORNO

REF.	DESCRIPCIÓN	OFERTA
CA-PRO25VX-57	Para compresores VX	8,93 €
CA-PRO24R1063	Para compresores directos (excepto VX)	6,83 €
CA-PRO6SILENT43	Para compresores silenciosos	6,83 €
CA-1127190009	Para compresores de correas (3HP)	16,28 €



CODO PARA COMPRESOR

REF.	DESCRIPCIÓN	OFERTA
CA-PRO24R1043	Para compresores directos	1,84 €
CA-PRO6SILENT47	Para compresores silenciosos	1,58 €
CA-1127080016	Para compresores de correas (3HP)	11,81 €



CE-EVOLUTION18X

230 V.
140 A
ø electrodo:
1,6-3,25 mm.
2,2 Kg.
56 V.
Kw 2,5 (45%)



139 €

CE-EVOLUTION20X

230 V.
160 A
ø electrodo:
1,6-4,0 mm.
2,5 Kg.
56 V.
Kw 3,9 (50%)



159 €

CE-MINI140X

230 V.
140 A
ø electrodo:
1,6-3,25 mm.
2 Kg.
62 V.
Kw 4,6



115 €

CE-KRONOS 155

230 V.
150 A
ø electrodo:
1,6-3,25 mm.
2,4 Kg.
56 V.
Kw 2,5 (45%)



149 €

CE-EVOMAX200

230 V.
200 A
ø electrodo:
1,6-4,0 (5) mm.
5,5 Kg.



169 €

CE-ULTRA170PLUS

230 V.
170 A
ø electrodo:
1,6-3,25 mm.
5 Kg.
56 V.

DIN 9-13



175 €

CE-ULTRA200PLUS

230 V.
200 A
ø electrodo:
1,6-4(5) mm.
6,9 Kg.
56 V.

DIN 9-13



209 €

CE-TITANIUM161

230 V.
160 A
ø electrodo:
1,6-4,0 mm.
6,44 Kg.
58 V.

TOP
LINE



219 €

CE-TITANIUM201

230 V.
200 A
ø electrodo:
1,6-5,0 mm.
6,44 Kg.
58 V.

TOP
LINE



259 €

CE-MAXMIG220

20-220 A
 ø Hilo acero 0,6-1,0 mm.
 ø Hilo acero 0,8-1,0 mm.
 ø Hilo acero 0,8-1,0 mm.
 Bobina max 15 Kg.
 (300 mm.)
 22 Kg.

Mig-Mag/MMA
 TIG-DC-LIFT
 Sinérgico



859€

CE-MAXMIG 270

20-250 A
 ø Hilo acero 0,6-1,2 mm.
 ø Hilo sin gas 0,8-1,2 mm.
 ø Hilo alu 0,8-1,2 mm.
 Bobina max 15 Kg.
 (300 mm.). 23Kg

Mig-Mag
 MMA
 TIG-DC-LIFT



999€

CE-PROMIG165

160 A.
 ø electrodo 1,6-3,25 mm.
 ø hilo max 1,0 mm.
 Bobina max 5 Kg.
 (200 mm.)
 6,44 Kg.

Mig-Mag
 MMA
 TIG-DC-LIFT



375€

CE-PROMIG200

200 A.
 ø electrodo:
 1,6-4 mm.
 ø hilo max 1,0 mm.
 Bobina max 5 Kg.
 (200 mm.). 12 Kg

Mig-Mag/MMA
 TIG-DC-LIFT
 Pantalla LCD
 Sinérgico



539€

CE-PROMIG 215

220 A.
 ø electrodo:
 1,6-4 mm.
 ø hilo max 1,0 mm.
 Bobina max 15 Kg.
 (200 mm.). 20 Kg

Mig-Mag/MMA
 TIG-DC-LIFT
 Pantalla LCD
 Sinérgico



799€

CE-PROMIG220

220 A.
 ø electrodo
 1,6-3,25 mm.
 ø hilo max 1,2 mm.
 Bobina max 15 Kg.
 (300 mm.)
 22 Kg.

Mig-Mag/MMA
 TIG-DC-LIFT
 Sinérgico

**TOP
 LINE**



999€

23

CE-PROMIG250PUL

220 A.
 ø electrodo:
 1,6-3,25 mm.
 ø hilo max 1,2 mm.
 Bobina max 15 Kg.
 (300 mm.)
 22 Kg.

Mig-Mag/MMA
 TIG-DC-LIFT
 Pulsado
 Sinérgico



1.899€

CE-PROMIG430SYN

300 A.
 ø electrodo:
 1,6-6 mm.
 ø hilo max 1,2 mm.
 Bobina max 15 Kg.
 (300 mm.)
 37 Kg.

Mig-Mag/MMA
 TIG-DC-LIFT
 Sinérgico

* Disponible
 a 380 V.



1.899€

CE-PROMIG440SYN

400 A.
 ø electrodo:
 1,6-8 mm.
 ø hilo max 1,6 mm.
 Bobina max 15 Kg.
 (300 mm.)
 42 Kg.

Mig-Mag/MMA
 TIG-DC-LIFT
 Sinérgico



2.475€

CE-PROMIG430PULSE

300 A.
 ø electrodo:
 1,6-6 mm.
 ø hilo max 1,2 mm.
 Bobina max 15 Kg.
 (300 mm.)
 39 Kg.

Mig-Mag/MMA
 TIG-DC-LIFT
Sinérgico



**TOP
 LINE**

2.499€

CE-PROMIG430AQU

300 A.
 ø electrodo:
 1,6-6 mm.
 ø hilo max 1,2 mm.
 Bobina max 15 Kg.
 (300 mm.)
 49 Kg.

Mig-Mag/MMA
 TIG-DC-LIFT
Sinérgico



3.499€

CE-PROMIG323

220 A
 ø electrodo:
 1,6-4,0 mm.
 ø hilo max 1,2 mm.
 Bobina max 15 Kg.
 (300 mm.)
 52 Kg.
 Incluye 2
 antorchas

Mig-Mag/MMA
 TIG-DC-LIFT
Sinérgico



1.889€

CE-PROMIG323/SG

220 A
 ø electrodo:
 1,6-4,0 mm.
 ø hilo max 1,2 mm.
 Bobina max 15 Kg.
 (300 mm.)
 52 Kg.
 Incluye 2
 antorchas
 + spool gun

Mig-Mag/MMA
 TIG-DC-LIFT
Sinérgico



SPOOL GUN M6
 TE-802407

2.368€

CE-PROMIG343WAV

220 A
 ø electrodo:
 1,6-4,0 mm.
 ø hilo max 1,2 mm.
 Bobina max 15 Kg.
 (3 uds.) (300 mm.)
 59 Kg.
 Incluye 3 antorchas.

Mig-Mag/MMA
 TIG-DC-LIFT
Pulsador



**TOP
 LINE**

3.399€

SPOOL GUN M6

Ref. TE-802407
 Bobina hilo aluminio 0,8 gr.
 Válido para mod. Promig 323.



524,57€

CE-TROLLEY

Válido para modelos Promig



109€

CE-TITANTIG200

230 V. 200 A
 ø electrodo 1,6-5,0 mm.
 56 V.
 Con accesorios incluidos
 7 Kg.

TIG-DC-HF
**Down time
 Post time**



329€

CE-TORCHAWP26 (4 mt.)
 De serie. P.V.P.: 72.45 €

CE-TORCHATIG8MT (8 mt.)
 Opcional. P.V.P.: 131.25 €

CE-GASCO2PLUS

Bombona. 1 Lt.
No recargable.
CO₂. (Para Acero)
Tara: 1.190 grs.
Test de presión: 145 Bar



22,05 €

CE-GASARGONPLUS

Bombona. 1 Lt.
No recargable.
Argón. (Para Aluminio)
Tara: 1.190 grs.
Presión a +20°: 110 Bar
Test de presión: 145 Bar

Para hilo de aluminio



22,05 €

CE-GASMIXTOPLUS

Bombona. 1 Lt.
No recargable.
CO₂ (20%) + Argón.(80%)
(Para Inoxidable)
Presión a +20°: 110 Bar
Test de presión: 145 Bar



22,05 €

TE-722119

Mano reductor para regular la presión de salida del gas.



56,57 €

CP-KITENLACE

Kit enlace para bombona (no recargable). Para conectar el inverter a la bombona de gas.



44,10 €

CE-CUT30 PFC

Corte 12 mm. 230 V.
100% Factor de trabajo



829 €

CE-CUT30 PFCK

Corte 12 mm. 230 V.
100% Factor de trabajo

Con compresor



1.049 €

CE-CUT40 PFCK

Corte 15 mm. 230 V.
100% Factor de trabajo

Con compresor



1.359 €

ACCESORIOS ANTORCHA CORTE PLASMA

DESCRIPCIÓN	REF.	OFERTA
1 BOQUILLA PORTA-BOQUILLAS	750000	19,95 €
2a BOQUILLA 0,8 mm (ESTÁNDAR)	750005	5,25 €
2b BOQUILLA 0,65 mm	750001	5,25 €
3 ANILLO DIFUSOR (5)	750002	16,80 €
4 ELECTRODO (3)	750003	5,25 €
5 CUERPO DE LA ANTORCHA	750006	192,15 €

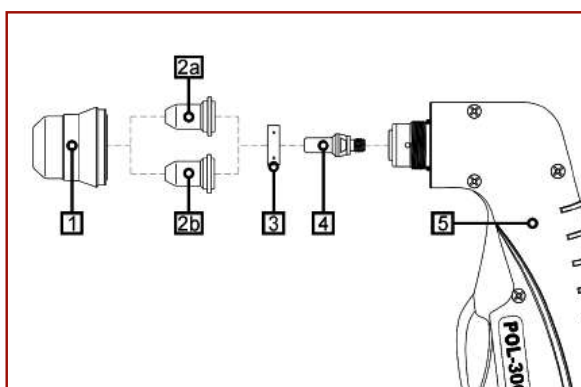

SP-3465K

230 V. 50 Hz
Potencia permanente 100% 12 Kva
Corriente salida máx. en corto: 1,8 Kva

4 Memorias



MADE IN EUROPE



599€

SP-TSW1000CAR

230 V. 50/60 Hz
Potencia Nominal 1.000 Kva
Capacidad 66 mf
4 Programas de soldadura
Pernos 2-6 ø mm.

Válida para aluminio



MADE IN EUROPE



1.599€

SP-3540

230 V. 50 Hz
Potencia permanente 100% 1,8 Kva
Corriente salida máx. en corto: 2,25 Kva

Pantalla LCD



MADE IN EUROPE



999€

SP-3541

400 V. 50 Hz
Potencia permanente 100% 1,8 Kva
Corriente salida máx. en corto: 4,5 Kva

Pantalla LCD



MADE IN EUROPE



999€

SP-3450

400 V. 50/60 Hz
Potencia máxima 50 Kva
Potencia nominal 50%: 10 Kva
Corriente máx. 8000 A
Protección alimentación: (retardo) 25A
Índice de protección: IP21
Peso: 105 Kg.



MADE IN EUROPE



3.799€

SP-8068

Pistola por puntos para mod.3540-3541



199€

SP-7633

Consumibles para mod. 3465K



93€

SP-7638

Extractor



59€

SP-3462

Carro válido para modelos 3465K, TSW1000CAR, 3540, 3541



145€

SP-24/1600

Arrancador portátil
Batería 12 V.
Amp. Arranque
1.600 A-P. L.E.



199€

SP-P5/2500

Arrancador portátil
Batería 12 V.
Amp. Arranque
2.500 A-P. L.E.



259€

SP-P01-TR-1224

Arrancador portátil
Batería 12-24 V.
Amp. Arranque
5.000-2.600 A-P. L.E.



850€

SP-P5/12-24V

Arrancador portátil
Batería 12-24 V.
Amp. Arranque
5.000-2.500 A-P. L.E.



1+1 mm.

599€

SP-H5HYBRID

Arrancador portátil
Batería 12 V.
Amp. Arranque
3.500 A-P. L.E.



2+2 mm.

349€

CE-FENIX20

Cargador alimentador
Batería 12-24 V.
9 Amp. 4,5A
115 Ah



55€

SP-LEM61211

Cargador/alimentador
Batería 6-12 V.
1,1 Amp.
1,1-100 Ah



2+2 mm.

49€

SP-LEM122470

Cargador/alimentador
Batería 12-24 V.
7-3,5 Amp.
225 Ah



79€

SP-LEM1224250

Cargador/alimentador
Batería 12-24 V.
25-12,5 Amp.
500 Ah



349€

SP-GX2

Cargador 12 V.
2.0 Ah
Carga máx.: 1,2 - 60 Ah.



Automático

47€

SP-GX5

Cargador 12 V.
5.0 Ah
Carga máx.: 1,2 - 110 Ah.



Automático

59,95€

SP-GX15

Cargador 12-24 V.
150 Ah
Carga máx.: 24 - 300 Ah.



Automático

171€

SP-MARS2415

Batería 12-24 V.
15 Amp.
200 Ah 100%
Cargador/alimentador



219€

SP-MARS2430

Batería 12-24 V.
30 Amp.
400 Ah 100%
Cargador/alimentador



299€

DEFENDER 12

230 V. - 62 W.
6 - 12 V.
2A/40 A
TE-807607

DEFENDER 20 BOOST

230 V. - 110 W.
12 - 24 V.
5A/180 A
TE-807600

ALASKA 150 START

Batería 12 V.
20 Amp.
10/200 Ah 100%
Cargador
TE-807576

Led

Tronic

28



41,43€

99,43€

103,57€

ALASKA 200 START

Batería 12-24 V.
25/12 Amp.
25/300 Ah 100%
Cargador
TE-807577

Led

Tronic

T-CHARGE12EVO

230 V. - 55 W.
6-12 V.
4 (12 V.) / 1 (6 V.)
4 (12 V.) / 1 (6 V.)
2/70 Ah
TE-807578

Pulse
Tronic

T-CHARGE20EVO

230 V. - 115 W.
12-24 V.
8 (12 V.) / 4 (6 V.)
8 (12 V.) / 4 (6 V.)
5/180 Ah
TE-807596

Pulse
Tronic



136,71€

78,71€

140,86€

MÁXIMA 160

20-150 A
 ø Hilo acero: 0,6-0,9 mm.
 ø Hilo sin gas/ alu:
 0,8-1,0 mm.
 Bobina max 5Kg.
 TE-816085

Mig-Mag



497,14€

MÁXIMA 190

20-170 A
 ø Hilo acero 0,6-0,8 mm.
 ø Hilo sin gas 0,8-1,2 mm.
 ø Hilo alu 0,8 -1 mm.
 Bobina max 5Kg.
 TE-816086

Mig-Mag/
 MMA
 TIG-DC-LIFT



559,29€

TELMIG 200/2

35-220 A
 ø Hilo acero 0,6-1,0 mm.
 ø Hilo alu 0,8-1,0 mm.
 TE-821056

Mig-Mag



994,29€

TELMIG 281/1

40-270 A
 ø Hilo acero 0,6-1,2 mm.
 ø Hilo alu 0,8-1,0 mm.
 TE-820099

Mig-Mag



1.346,43€

MASTERMIG 300

40-300 A
 ø Hilo acero 0,6-1,2 mm.
 ø Hilo inox 0,6-1,2 mm.
 ø Hilo alu 0,8-1,0 mm.
 TE-827003

Mig-Mag



2.195,71€

MASTERMIG 400

40-400 A
 ø Hilo acero 0,6-1,6 mm.
 ø Hilo inox 0,6-1,6 mm.
 ø Hilo alu 0,8-1,2 mm.
 TE-827004

Mig-Mag



2.589,29€

MASTERMIG 500

40-300 A
 ø Hilo acero 0,6-2,0 mm.
 ø Hilo inox 0,8-2,0 mm.
 ø Hilo alu/bz 0,8-1,2 mm.
 TE-827007

Mig-Mag



3.210,71€

MASTERMIG 500 Aqua

40-300 A
 ø Hilo acero 0,6-2,0 mm.
 ø Hilo inox 0,8-2,0 mm.
 ø Hilo alu/bz 0,8-1,2 mm.
 TE-822008

Mig-Mag



4.205€

ELECTROMIG 450

20-400 A
 ø Hilo acero 0,6-2,0 mm.
 ø Hilo inox 0,8-2,0 mm.
 ø Hilo alu 0,8-1,6 mm.
 ø Hilo bz 0,8-1,6 mm.
 TE-816190

Mig-Mag/MMA
 TIG-DC-LIFT
 Sinérgico



**CONSULTAR
 PRECIO**

ELECTROMIG 550 Aqua

20-500 A
 ø Hilo acero
 0,6-2,4 mm.
 ø Hilo inox
 0,8-2,4 mm.
 ø Hilo alu
 0,8-1,6 mm.
 ø Hilo bz
 0,8-1,2 mm.
 TE-816194



**Mig-Mag/MMA
 TIG-DC-LIFT
 Sinérgico**



**CONSULTAR
 PRECIO**

INFINITY PLASMA 40

10-40 A - 230V.
 Corte máx. 15 mm. 100 Lt/min
 Bar 4-5 - 29 amp - máx
 40 amp - 20%
 TE-816145

12 mm.



621,43€

TECHNOLOGY PLASMA 60XT

10-60 A - 230V.
 Corte máx. 20 mm - 100 Lt/min
 ø Hilo Bar 4-5 - 34 amp - máx
 50 amp - 20%
 TE-816148

18 mm.



1.035,71€

SUPERIOR PLASMA 70

230V. - 13 amp-máx - 70-30A
 16 amp-máx - 50-35 A
 Corte máx. 30 mm.
 200 Lt/min - Bar 4-5
 TE-816170



2.175 €

SUPERIOR PLASMA 100

230V. - 23,7 amp - 100-30A
 20,8 amp - 70-30 A
 Corte máx. 40 mm.
 290 Lt/min - Bar 4-5
 TE-816172



3.417,86€

SUPERIOR PLASMA 160

400V. 100-30 A - 38 amp
 40 amp - 150-30A
 Corte máx. 50 mm.
 290 Lt/min - Bar 4-5
 TE-816174



**CONSULTAR
 PRECIO**

TECHNOLOGY TIG 182

230 V. - 4,3 KW.
 5 -160 A
 Corriente al 50%
 85 A.
 ø electrodo: 1,6 - 3,2 mm.
 TE-852030

**Tig-AC-DC
 MMA**



1.781,43€

TECHNOLOGY TIG 222

230 V. - 5,5 KW.
 5 -200 A
 Corriente al 50%
 100 A.
 ø electrodo: 1,6 - 4,0 mm.
 TE-852054

**Tig-AC-DC
 MMA**



2.050,71€

CLEANTECH 200

Limpiador soldadura 230 V.
 2 Posiciones
 de regulación
 TE-850020



621,43€

DIGITAL PULLER 5500

400 V. - 10,5 Kw.
Fusible de red 10 A.
5,5 V. - 3.800 A
TE-828128



621,43 €

DIGITAL PULLER 5500

230 V. - 10,5 Kw.
Fusible de red 16 A.
5,5 V. - 3.800 A
TE-828127



642,14 €

DIGITAL PULLER 5500 DUO

230 V. - 5,6 V.
10,5 Kw.
3.800 A
TE-828131



**CONSULTAR
PRECIO**

MODULAR 20/TI

230 V. - 6 Kw.
Fusible de red
16 A. - 2 V.
3.800 A
TE-823015

1+1 mm.



580 €

DIGITAL MODULAR 230

230 V. - 13 Kw.
Fusible de red
25 A. - 2,5 V.
6.300 A
TE-823016

2+2 mm.



725 €

DIGITAL MODULAR 400

400 V. - 13 Kw.
Fusible de red
16 A. - 2,5 V.
6.300 A
TE-823017

2+2 mm.



745,71 €

31

SPRINTER 3000 START

230 V.
12-24 V.
45 A.
300 A.
20/700 Ah.
TE-829390



266,14 €

SPRINTER 4000 START

230 V.
12-24 V.
75 A.
400 A.
20 /1.000 Ah
TE-829391



331,43 €

SPRINTER 6000 START

230 V.
12-24 V.
90 A.
570 A.
20 /1.550 Ah
TE-829392



397,71 €

STUDDER BOX
TE-143780



77,14 €

STUDDER READY BOX
TE-143722



44,23 €

KIT CONSUMIBLES
DENT PULLING
TE-802838

54,51 €



DENT PULLING BOX
TE-802690



67,89 €

32

ESTRELLAS	CODIGO	OFERTA
ESTRELLAS FE-CU	TE-802296 100 uds.	43,20 €
MANDRIL	TE-722954	8,23 €

RECALCADO	CODIGO	OFERTA
ELECTRODO	TE-722963	7,20 €

REMIENDO	CODIGO	OFERTA
ELECTRODO	TE-722964	33,94 €

SOLDADURA 1 LADO	CODIGO	OFERTA
ELECTRODO	TE-742485	19,29 €

REMACHES M5 - Ø5	CODIGO	OFERTA
18 mm.	TE-802301 100 uds.	12,34 €
10 mm.	TE-802299 100 uds.	10,29 €
12 mm.	TE-802302 100 uds.	12,34 €
25 mm.	TE-802304 100 uds.	12,96 €
ELECTRODO M5 - M6	TE-722959	13,37 €

REMACHES (M4)	CODIGO	OFERTA
15 mm	TE-802300 100 uds.	9,67 €
ELECTRODO	TE-722958	20,57 €

REMACHES (Ø3)	CODIGO	OFERTA
3,2 mm	TE-802297 100 uds.	6,79 €
4,5 mm	TE-802298 100 uds.	6,70 €
ELECTRODO	TE-742484	14,40 €

HILO ONDULADO	CODIGO	OFERTA
300 mm	TE-802339 100 uds.	25,57 €
200 mm	TE-802728 50 uds.	20,57 €
POSICIONADOR	TE-742087	37,03 €

CALENTAMIENTO	CODIGO	OFERTA
150 mm CARBON	TE-802608 5 uds.	6,49 €

ARANDELAS	CODIGO	OFERTA
Ø 8 mm	TE-802295 100 uds.	6,17 €
MANDRIL	TE-722955	14,40 €

ARANDELAS CON GANCHO	CODIGO	OFERTA
ARANDELAS RECTAS	TE-802943 50 uds.	15,43 €
ARANDELAS DOBLADAS	TE-802944 50 uds.	18,51 €
ELECTRODO	TE-742541	24,69 €
210mm PALANCA	TE-484244	3,61 €
410mm PALANCA	TE-484635	4,11 €

CLAVOS	CODIGO	OFERTA
Ø 2x50 mm	TE-802293 100 uds.	6,17 €
Ø 2,6x50 mm	TE-802294 100 uds.	8,23 €
ELECTRODO	TE-742486	14,40 €
MANDRIL	TE-722953	86,40 €

MASA PARA PUNTEADO	CODIGO	OFERTA
-	TE-802462	12,34 €

MT15

Antorcha para soldadura con hilo. Disponible en 2, 3 y 4 mt.



REF.	DESCRIPCIÓN	OFERTA
CE-AX15/2MALU	ALUMINIO	93,45 €
CE-AX15/3M	ACERO, INOX, FLUX	72,45 €
CE-AX15/4M	ACERO, INOX, FLUX	78,75 €

MT25

Antorcha para soldadura con hilo. Disponible en 2, 3, 4 y 5 mt.



REF.	DESCRIPCIÓN	OFERTA
CE-AX25/2MALU	ALUMINIO	103,95 €
CE-AX25/3M	ACERO, INOX, FLUX	84,00 €
CE-AX25/4M	ACERO, INOX, FLUX	89,25 €
CE-AX25/5M	ACERO, INOX, FLUX	99,75 €

MT36

Antorcha para soldadura con hilo. Disponible en 3, 4 y 5 mt.



REF.	DESCRIPCIÓN	OFERTA
CE-AX36/3M	ACERO, INOX, FLUX	126,00 €
CE-AX36/4M	ACERO, INOX, FLUX	178,50 €
CE-AX36/5M	ACERO, INOX, FLUX	183,75 €

ACCESORIOS ANTORCHAS DE HILO MT

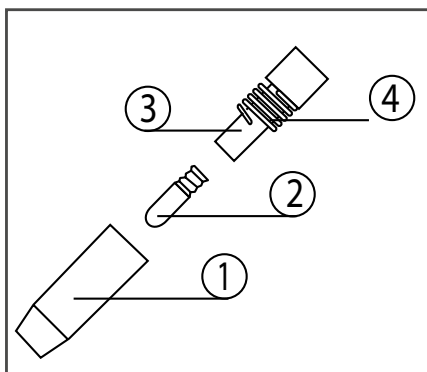

1 - TOBERA

2 - PUNTAS DE CONTACTO



3 - DIFUSOR

4 - MUELLE



KIT CP-KITMT15 Contenido:

Nº	REFERENCIA	DESCRIPCIÓN
1	CP-KITTOBERA	2 Toberas
2	CP-PUNTA0,8	5 Puntas de acero de 0,8 mm.
2	CP-PUNTA1,0	5 Puntas de acero de 1,0 mm.
2	CP-PUNTA1,0ALU	5 Puntas de aluminio y animado 0,9 y 1,0 mm.
3	CP-DIFUSOR15	2 Difusores
4	CP-MUELLE15	2 Muelles

15,75 €

REPUESTOS PARA KIT CP-KITMT15

REFERENCIA	OFERTA
CP-KITTOBERA	8,40 €
CP-PUNTA0,8	6,30 €
CP-PUNTA1,0	5,25 €
CP-PUNTA1,0ALU	8,40 €
CP-DIFUSOR15	6,30 €
CP-MUELLE15	2,10 €

KIT CP-KITMT25 Contenido:

Nº	REFERENCIA	DESCRIPCIÓN
1	CP-KITTOBERA25	2 Toberas
2	CP-PUNTA0,825	5 Puntas de acero de 0,8 mm.
2	CP-PUNTA1,025	5 Puntas de acero de 1,0 mm.
2	CP-PUNTA1,0AI25	5 Puntas de aluminio y animado (0,9) de 1,0 mm.
3	CP-DIFUSOR25	2 Difusores
4	CP-MUELLE25	2 muelles

19,95 €

REPUESTOS PARA KIT CP-KITMT25

REFERENCIA	OFERTA
CP-KITTOBERA25	9,45 €
CP-PUNTA0,825	8,40 €
CP-PUNTA1,025	7,35 €
CP-PUNTA1,0AL25	7,88 €
CP-DIFUSOR25	9,45 €
CP-MUELLE25	4,83 €

ROLDANA

Rodillo de arrastre para equipo de hilo.

REFERENCIA	PARA	MEDIDAS	PARA MODELO	OFERTA
CE-PROMIG200-AL	HIERRO / ALUMINIO / FLUX	0,8 - 1,0 mm.	PROMIG 165/200	18,90 €
CE-ROLDA-PROMIG	HIERRO / ALUMINIO / FLUX	0,6 - 0,8 mm.	PROMIG 165/200	16,80 €
TE-742090	ALUMINIO	0,8 - 1,0 mm.	PROMIG 220	18,90 €
TE-722112	ACERO	0,6 - 0,8 mm.	PROMIG 220	18,90 €
TE-742054	ACERO	1,0 - 1,2 mm.	PROMIG 220	15,75 €
TE-722130	FLUX	1,0 - 1,2 mm.	PROMIG 220	30,45 €
TE-722019	ALU-FE	0,6 - 0,8 mm.	MAXMIG 220	9,45 €
TE-722627	ALU-FE	1,0 mm.	MAXMIG 220	7,35 €
TE-722529	FLUX	0,6 - 0,9 mm.	MAXMIG 220	13,65 €

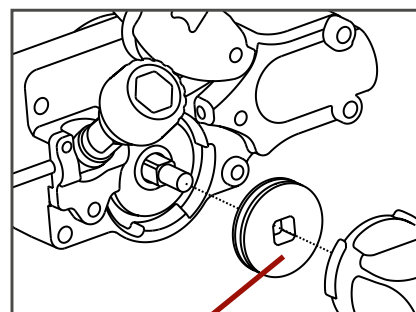

ROLDANA

CE-PANTALLA410

Ligera
 Área de visión:
 105x50 mm.
 Din 12



6,50€

CP-PANTALLA2

Pantalla tipo casco
 Área de visión:
 110x90mm.
 Clase Optica 1
 Din 11



8,40€

CE-PE400S

Automática. Regulable 9-13
 Área de visión:
 92x35 mm.
 Clase Optica
 1/1/1/2



32€

CE-PE800PRO

Automática. Regulable 9-13
 Área de visión:
 92x42 mm.
 Clase Optica
 1/1/1/2



42€

CE-STARWHITE

Automática.
 Regulable 9-13
 Área de visión:
 98x43 mm.
 Clase Optica
 1/1/1/2

**Batería
 recambiable**



55€

CE-PE903XL

Automática. Regulable
 5-9 / 9-13
 Área de visión:
 100x67 mm.
 Clase Optica
 1/1/1/1

**Batería
 recambiable
 Visión 180°**



69€

CE-PE904XL

Automática
 Regulable
 5-9 / 9-13
 Área de visión:
 100x67 mm.
 Clase Optica
 1/1/1/1

**Batería
 recambiable
 Visión 180°**



69€

CE-PE1000/3XL

Automática.
 Regulable
 4-8 / 8-12
 Área de visión:
 115x85 mm.
 Clase Optica
 1/1/1/1 - 1/1/1/2

**Batería
 recambiable
 Visión 180°**



199€

BOBINAS DE HILO (MIG)

REFERENCIA	HILO	Ø	CAPACIDAD BOBINA (Kgs)	OFERTA
CP-HILOANIMO,9N	Animado	0,9 mm.	0,8	15,75 €
CP-HILOACE0,8	Acero	0,8 mm.	0,8	10,45 €
CP-HILOINOX0,8	Inoxidable	0,8 mm.	0,8	19,95 €
CP-HILOANIM3KG	Animado	0,8 mm.	3	68,25 €
CP-HILOALU0,8	Aluminio	0,8 mm.	0,5	19,95 €
CP-HILOACE5KG	Acero	0,8 mm.	5	36,75 €



ELECTRODOS RUTILO (CAJA)

REFERENCIA	CARACT.	MEDIDAS	OFERTA
CP-RU2,0CAJA50	50 uds.	2,0 mm.	4,20 €
CP-RU2,5CAJA50	50 uds.	2,5 mm.	4,20 €
CP-RU3,25CAJA50	50 uds.	3,25 mm.	7,35 €
CP-RU2,0CAJA200	200 uds.	2,0 mm.	11,55 €
CP-RU2,5CAJA225	225 uds.	2,5 mm.	14,70 €
CP-RU3,25CAJ140	140 uds.	3,25 mm.	15,75 €
CP-RU4,0CAJ100	100 uds.	4,0 mm.	15,75 €



ELECTRODOS RUTILO (BLISTER)

REFERENCIA	CARACT.	OFERTA
CP-RU1,6BLIS	30 uds. 1,6 mm.	5,52 €
CP-RU2,0BLIS	20 uds. 2 mm.	3,15 €
CP-RU2,5BLIS	20 uds. 2,5 mm	3,15 €
CP-RU3,25BLIS	20 uds. 3,25 mm.	3,15 €

ELECTRODO BÁSICO (BLISTER)

REFERENCIA	CARACT.	OFERTA
CP-BA2,5BLIS	20 uds. 2,5 mm.	4,20 €



ELECTRODOS PARA INOXIDABLE/ALUMINIO (BLISTER)

REFERENCIA	CARACT.	OFERTA
CP-INOX2,0	10 ELEC. INOX 2.0 mm.	11,55 €
CP-INOX2,5	10 ELEC. INOX 2.5 mm.	11,55 €
CP-INOX3,25	10 ELEC. INOX 3.25 mm.	13,65 €
CP-ALU2,5	10 ELEC. ALU. 2.5 mm.	12,60 €
CP-ALU3,25	10 ELEC. ALU. 3.25 mm.	16,80 €



ELECTRODOS TIG

REFERENCIA	CARACT.	OFERTA
Electrodo GRIS. Tungsteno/Cerio al 2%.		
CE-TIGINOX1,6T	Pack 2 uds. 1,6 mm	9,45 €
TE-802220	Caja 10 uds. 1,0 mm.	14,65 €
TE-802222	Caja 10 uds. 1,6 mm	28,80 €
TE-802232	Caja 10 uds. 2,4 mm	59,85 €
TE-802233	Caja 10 uds. 3,2 mm	103,95 €
Electrodo VERDE. Tungsteno Puro. CA. WP		
TE-802234	Caja 10 uds. 1,0 mm	16,46 €
TE-802235	Caja 10 uds. 1,6 mm	27,77 €
TE-802236	Caja 10 uds. 2,4 mm	61,71 €
TE-802237	Caja 10 uds. 3,2 mm	103,95 €

35

PINZAS MASA

REFERENCIA	CARACT.	OFERTA
CP-PINZAM150A	150A.	3,15 €
CP-PINZAM300A	300A.	5,25 €
CP-PINZAM400A	400A.	6,30 €
CP-PINZAM600A	600A.	9,45 €



PINZAS PORTAELECTRODOS

REF.	CARACT.	OFERTA
CP-PINZA150A	150A.	7,35 €
CP-PINZA300A	300A.	12,60 €
CP-PINZA400A	400A.	13,65 €
CP-PINZA600A	600A.	14,70 €



ANTORCHAS TIG

REF.	Ø mm.	OFERTA
CE-TORCHA	25	82,95 €
CE-TORCHA50	50	93,45 €
CE-TORCHATIG8MT	50	131,25 €



ESCUADRA MAGNÉTICA

REF.	OFERTA
CP-ESCUADRA	7,35 €

Soporta hasta 22 kg.



PIQUETAS

Especial para soldador.

REF.	CARACT.	OFERTA
CP-PIQUETA	Mango madera	6,20 €
CP-PIQUETAH	Mango hierro	7,88 €



CE-SPRAY

Spray antiadherente para eliminación de proyecciones de soldadura y escorias. Sin Silicona.

7,35€



CONECTORES

REFERENCIA	CARACT.	OFERTA
CP-CONEC25M	25 mm. (2 uds.) Macho	6,30 €
CP-CONEC50M	50 mm. (1 ud.) Macho	10,50 €
TE-804196	25 mm. (1 ud.) Hembra	2,63 €
TE-804197	50 mm. (1 ud.) Hembra	5,25 €



CABLES DE COBRE

Especial para soldadura.

REFERENCIA	CARACT.	OFERTA
CP-CABLEPRO16	10 m. 16 mm ² .	37,80 €
CP-CABLEPRO25	10 m. 25 mm ² .	51,45 €



CP-085R

Guantes serraje vacuno natural con manguito de 15 cm. Longitud total: 34,5 cm. Talla 10.

Espesor de piel 1,1 mm



4,73€

CP-123/1

Delantal de serraje vacuno natural de una pieza. (90x60 cm.)

Espesor de piel 1,1 mm



16,80€

TE-802632

Guantes serraje profesional para soldadura TIG. Serraje anti-calórico e hidrófugo. Forro no inflamable. Largo: 45 cm. Talla 10.

Espesor de piel 1,3 mm



32,91€

CE-104K

Kit de soldadura con:

- Pantalla de soldar con cristal incluido 50X105 mm.
- Par de guantes de vacuno de 1,1 mm. de espesor de piel.
- Escuadra magnética 4" soporta hasta 22 Kg.
- Escuadra magnética 3" soporta hasta 15 Kg.



24,15€

KITS Y PANTALLAS PARA SOLDADURA

Kit pantalla protectora separadora. Soporte de metal. Con ruedas. Protegen de UV, arcos ligeros y chispas. Peso: 7,8 Kg.

REF.	CARACTERISTICAS	OFERTA
TE-802676	Pantalla individual roja	59,66 €
TE-802677	Pantalla individual verde	59,66 €
TE-803508	Kit pantalla de protección + soporte 1850x670x1950mm.	154,29 €
TE-803509	Kit pantalla de protección + soporte 1850x670x1950mm.	154,29 €



TE-803508



TE-803509

CE-M1201PRO

1200 W.
Volumen mezcla 40 Lt.
150-300 r.p.m.
300-650 r.p.m.
Regulación electrónica



95 €

CE-M1600PRO

1600 W.
Volumen mezcla 120 Lt.
210-390 r.p.m.
350-650 r.p.m.
Regulación electrónica



109 €

2 velocidades

VARILLAS PARA BATIDORA

CE-H2A - 120x600 mm. - M14
CE-H2B - 140x600 mm. - M14
CE-H3A - 120x600 mm. - M14
CE-H3B - 140x600 mm. - M14
CE-H5B - 140x600 mm. - M14

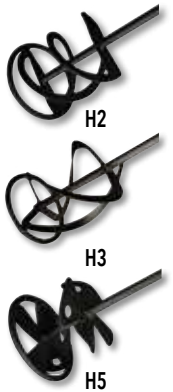

UD. DESDE
14,18 €

VARILLAS PARA TALADRO

CE-VARILLA 80X400
CE-VARILLA 100X600



UD. DESDE
2,63 €

CE-MX1601N

1600 W.
Volumen mezcla 120 Lt.
150-300 r.p.m.
300-650 r.p.m.
Regulación electrónica



129 €

2 velocidades

Uso profesional



MALETA DE PLÁSTICO

CE-MX1801N

1800 W.
Volumen mezcla 140 Lt.
150-300 r.p.m.
300-650 r.p.m.
Regulación electrónica



149 €

2 velocidades

Uso profesional



MALETA DE PLÁSTICO

CE-M900R

850 W.
Volumen mezcla 40 Lt.
0-550 r.p.m.
M14



65 €

37

CE-GW1026M

2000 W. 50-550 °C
2 velocidades
300 - 500 Lt/min
6 accesorios.



22 €



MALETA DE PLÁSTICO

CE-GW1029M

2000 W. 50-600 °C
2 velocidades
300 - 500 Lt/min
9 accesorios.



35 €



MALETA DE PLÁSTICO

Sistema de enfriamiento

Display LCD

CE-GW1030M

2000 W. 50-600 °C
2 velocidades
200 - 500 Lt/min
9 accesorios.



49 €



MALETA DE PLÁSTICO

Display digital

CAUCHO

F-88001T

Cubo italiano
10 Lt. 1,3 kgs.



7,59€

F-880012

Espuerta 11 Lt.
40x13,4 cm.



7,50€

F-8812PICO

Cubo de obra con pico.
12 Lt. 1,8 Kg.



9,99€

F-880011

Gaveta 12 Lt.
52,7x41,7x15,2 cm.



9,99€

F-880028

Carbonera
20 Lt.
47,2x16,4 cm.



13,30€

F-880030

Espuerta
30 Lt.
43x27,5 cm.



13,50€

38

F-880015

Gaveta 15 Lt.
54,6x43,6x16,8 cm.



13,30€



PLÁSTICO

F-880003

Cubeta 3 Lt.
32x22x6,5 cm.



1,65€

CU-CALDERETA11

Caldereta 10 Lt.
Alto: 13 cm.
Boca: 32 cm.



2,60€

CU-CAPAZO

Capazo 42 Lt.
Alto: 33 cm.
Boca: 44 cm.



3,10€

CU-CAPAZO55

Capazo 55 Lt.
Alto:33 cm. Boca: 53 cm.



4,25€

CP31-750

Lijadora de pared
750 W. Ø Disco lija 225 m.
6 velocidades
Telescópica: 110/180 cm.



179 €

CP31-1100

Lijadora de pared
1010 W. Ø Disco lija 225 m.
6 velocidades.



114 €

HV651

Equipo de pintar. 280 W.
Depósito 600 ml.
Viscosidad máx. 90 Din/sec

3 posiciones



59 €

CP31-400

Lijadora roto orbital
230-240 V.
ø lija 150 mm.
400 - 10000 r.p.m.

Motor "Brushless"
Orbita 5 mm.



199 €

Plato de goma
ø 150 mm.
Ref.: NE-RP733651BIS
P.V.P.:34,00 €



CP31-401

Lijadora roto orbital
230-240 V.
ø lija 150 mm.
400 - 10000 r.p.m.

Motor "Brushless"
Orbita 2,5 mm.



199 €

Plato de goma
ø 150 mm.
Ref.: NE-RP733651BIS
P.V.P.:34,00 €



39

DISCOS DE LIJA

Discos de lija con velcro de gran calidad. ø 150 mm. 15 agujeros. Válidos para modelos CP31-400 / CP31-401

ARTICULO	GRANO	OFERTA	ARTICULO	GRANO	OFERTA	ARTICULO	GRANO	OFERTA
IM-ICARVF402040	40	0,52 €	IM-ICARVF402150	150	0,34 €	IM-ICARVF402320	320	0,34 €
IM-ICARVF402060	60	0,48 €	IM-ICARVF402180	180		IM-ICARVF402400	400	
IM-ICARVF402080	80	0,41 €	IM-ICARVF402220	220		IM-ICARVF402500	500	
IM-ICARVF402100	100	0,37 €	IM-ICARVF402240	240		IM-ICARVF402600	600	
IM-ICARVF402120	120	0,37 €	IM-ICARVF402280	280		IM-ICARVF402800	800	

Cajas completas (100/50 uds.)



CP12-921

350 W.
Capacidad de la broca 1,5 - 13 mm.
Altura: 580 mm.
Portabrocas B13

Portabrocas llave
Mordaza



119 €

CP12-941

450 W.
Capacidad de la broca 3 - 16 mm.
Altura: 840 mm.
Portabrocas B16

Portabrocas automático
Mordaza



219 €

CP12-951

550 W.
Capacidad de la broca 23 MT2 (*)
(Brocas cónicas)
Altura: 980 mm.
Portabrocas B16

Portabrocas automático
Mordaza



319 €

CP12-953

750 W.
Capacidad de la broca 28 MT3 (*)
(Brocas cónicas)
Altura: 1600 mm.
Portabrocas B22

Portabrocas automático
Mordaza



440 €

CP12-961

1500 W.
Capacidad de la broca 32 MT4 (*)
(Brocas cónicas)
Altura: 1710 mm.
Portabrocas B22

Portabrocas automático
Mordaza



799 €

PORTABROCAS

Para taladros de columna.

REFERENCIA	OFERTA
CP12-903 (B13 de 1.5 a 13 mm.)	21,00 €
CP12-904 (B16 de 3 a 16 mm.)	31,00 €
CP12-909 (B22 de 5 a 20 mm.)	37,00 €



(*) 23 MT2: Brocas cónicas de 15 a 23 mm.

(*) 28 MT3: Brocas cónicas de 23 a 28 mm.

40

MORDAZAS

Para taladros de columna.

MORDAZAS	OFERTA
CP12-906 (55 mm.)	16,00 €
CP12-901(100 mm.)	16,00 €
CP12-902 (150 mm.)	31,00 €



CE-CTS250M

1500 W.
5700 r.p.m. Altura de corte: 73/48 mm.

Disco ø 250 mm.



199,95 €

Accesorios

Disco DM25030Z42 P.V.P. 25,00 €
Disco DM25030Z60 P.V.P. 51,00 €



CP36-521R

1800 W.
5700 r.p.m. Altura de corte: 73/54 mm.

Disco ø 250 mm.



289,95 €

Accesorios

Disco DM25030Z42 P.V.P. 25,00 €
Disco DM25030Z60 P.V.P. 51,00 €



CE-P125-250

Polipasto. 540 W.
125/250 Kg. Largo cable:
12,5/6,25 m.



114 €

CE-P250-500

Polipasto. 1020 W.
250/500 Kg. Largo cable:
18,5/9,25 m.



169 €

CE-P500-990

Polipasto. 600 W.
500/990 Kg. Largo cable:
12,5/6,25 m.



299 €

CE-B750

Bandera para polipasto
• 250 Kgs. MÁX.
• Largo bandera 750 mm.
• Ángulo de rotación
180 grados.



45 €

CE-B1100

Bandera para polipasto
• 600 Kgs. MÁX.
• Largo bandera 1.100 mm.
• Ángulo de rotación
180 grados.



49 €

CE-E25/150

Esmeriladora doble muela
Ø 150 mm. 150 W.
2.900 r.p.m.



43 €

CP10-200

Esmeriladora doble muela
Ø 200 mm. 500 W.
2.950 r.p.m.



69,95 €

CP10-150AGUA

Esmeriladora afiladora
de agua. Motor 400 W.
2.950 r.p.m.

Doble muela



69,95 €

CP10-150LIJA

Esmeriladora lijadora.
Motor 450 W.
2.950 r.p.m.

2 en 1



79,95 €

ACCESORIOS

MORDAZAS	OFERTA
CE-MUELAAGUA200	57,85 €
CE-MUELA150GR36	14,00 €
CE-MUELA150GR60	14,00 €
CE-MUELA200GR36	17,00 €
CE-MUELA200GR60	17,00 €
IMBANDA50X680	14,00 €



CP31-501
2200 W.
Depósito 30 Lt.
Regulación electrónica
Acc. incluidos

Especial pintura
Telecomandado
Aspira sólidos y líquidos
Filtro de agua



269 €

CE-PRO20X
1250 W.
Caudal aire:
58 Lt/s
Depósito: 20 Lt.
Acc. incluidos

Depósito acero inox.
Aspira sólidos y líquidos



83 €

CE-PRO30XT
1400 W.
Caudal aire:
58 Lt/s
Depósito: 30 Lt.
Acc. incluidos

Depósito acero inox.
Telecomandado
Aspira sólidos y líquidos



125 €

CE-PRO50XT
1.400 W.
Caudal aire:
58 Lt/s
Depósito: 50 Lt.
Acc. incluidos

Depósito acero inox.
Telecomandado
Aspira sólidos y líquidos



155 €

CE-PRO70ABS
1200 W.
Caudal aire:
215 m3/h.
Depósito: 77 Lt.
65 dB.
Acc. incluidos

Depósito Polipropileno
Aspira sólidos y líquidos



309 €

CE-PRO703INOXTR
2900 W.
Caudal aire:
510 m3/h.
Depósito: 77 Lt.
Acc. incluidos

Depósito acero inox.
3 motores
Aspira sólidos y líquidos



559 €

CE-PRO703ABS
2900 W.
Caudal aire: 510 m3/h.
Depósito: 77 Lt. 68 dB.
Acc. incluidos



Depósito Polipropileno
3 motores
Aspira sólidos y líquidos



515 €

VCX30-1500PEINOX

Depósito 30 Lt.
1.250 W.
Aire aspirado
260 m³/h.



166 €

Depósito acero
inox.
Telecomandado
Aspira sólidos y
líquidos

VCX50-1500PEINOX

Depósito 50 Lt.
1.250 W.
Aire aspirado
260 m³/h.



219 €

Depósito acero
inox.
Telecomandado
Aspira sólidos y
líquidos

VCX70-1500PEINOX

Depósito 76 Lt.
1.250 W.
Aire aspirado
260 m³/h.



326 €

Depósito acero
inox.
Telecomandado
Aspira sólidos y
líquidos

VCX70-3000BI3INOX

Depósito 76 Lt.
1.100 W.x3
Aire aspirado
520 m³/h.



543 €

Depósito acero
inox.
3 motores
Aspira sólidos
y líquido

VCX70-3000BI3ABS

Depósito 76 Lt.
1.100 W.x3
Aire aspirado
520 m³/h.



499 €

Depósito ABS
3 motores
Aspira sólidos
y líquidos

VCX70-2000BSEXINOX

Depósito 76 Lt.
Boquilla para
Tapicería
Manguera 2,5 mt
Hidrolítica



943,95 €

Depósito acero
inox.
Lavamoquetas

VCX20

Aspirador de cenizas
Depósito 20 Lt.
900 W.
Botón de
agitador filtro



42 €

VCX30-1500EXINOX

Boquilla para
tapicería.
Depósito 30 Lt.
1200 W.



502,95 €

Depósito acero
inox.
Lavamoquetas

MODELO	CP31-501	PRO20X	PRO30XT	PRO50XT	PRO70ABS	PRO703INOX	PRO703ABS
BOLSA	CP31-501BOLSA	AS1001	AS1001	AS1002	FI005C	FI005C	FI005C
	21,00 €	12,60 €	12,60 €	14,70 €	12,60 €	12,60 €	12,60 €
FILTRO SÓLIDO	CP31-501FP	AS1008	AS1008	AS1008	FA044P	FA044P	FA044P
	20,94 €	14,70 €	14,70 €	14,70 €	44,10 €	44,10 €	44,10 €
FILTRO LÍQUIDO	CP31-501FA	AS1005	AS1005	AS1005	ACCA165A	ACCA165A	ACCA165A
	11,55 €	10,50 €	10,50 €	10,50 €	12,60 €	12,60 €	12,60 €
MANGUERA	CP31-501-52	AS1001PRO	AS1001PRO	AS1001PRO	CE-ACTF38/2.5/C	CE-ACTF38/2.5/C	CE-ACTF38/2.5/C
	12,50 €	9,45 €	9,45 €	9,45 €	31,50 €	31,50 €	31,50 €
PROLONGADOR PLÁSTICO		AS1002AKP	AS1002AKP	AS1002AKP			
		6,30 €	6,30 €	6,30 €			
PROLONGADOR METÁLICO		AS1004EKP	AS1004EKP	AS1004EKP	ACTC038D	ACTC038D	ACTC038D
		12,60 €	12,60 €	12,60 €	27,30 €	27,30 €	27,30 €
BOQUILLA		AS1009EKB	AS1009EKB	AS1009EKB	CE-ACLP040	CE-ACLP040	CE-ACLP040
		6,30 €	6,30 €	6,30 €	4,20 €	4,20 €	4,20 €
CEPILLO MULTIUSO		AS1004EKB	AS1004EKB	EKB1002			
		14,70 €	14,70 €	14,70 €			
SOPORTE CEPILLO					ACCS400A/P	ACCS400A/P	ACCS400A/P
					11,55 €	11,55 €	11,55 €
CEPILLO LÍQUIDOS					ACIL400	ACIL400	ACIL400
					11,40 €	11,40 €	11,40 €
CEPILLO SUELOS					ACIP400	ACIP400	ACIP400
					10,50 €	10,50 €	10,50 €
CEPILLO REDONDO 40					ACPE040	ACPE040	ACPE040
					5,25 €	5,25 €	5,25 €

MODELO	VCX30PEINOX	VCX50PEINOX	VCX70PEINOX	VCX70 30003INOX	VCX70 3000BI3ABS	VCX30 1500EXINOX	VCX70 2000BSEXIMNOX	VCX20
BOLSA MICROFIBRA	CA-1129000037	CA-1129003552	CA-1129003552	CA-1129003552	CA-1129003552			CA-1129000036
	5,25 €	15,75 €	15,75 €	15,75 €	15,75 €			19,95 €
FILTRO SÓLIDO	CA-1129000036	CA-1129000036	CA-1129003554	CA-1129003553	CA-1129003553			CA-1129000036
	19,95 €	19,95 €	31,50 €	34,65 €	34,65 €			19,95 €
FILTRO LÍQUIDO	CA-1129000007	CA-1129000007	CA-1129003555	CA-1129003555	CA-1129003555	CA-1129000007	CA-1129003555	
	4,20 €	4,20 €	11,55 €	11,55 €	11,55 €	4,20 €	11,55 €	
MANGUERA	CA-1129000035	CA-1129000035	CA-1129000011	CA-1129000011	CA-1129000011	CA-1129003556	CA-1129003557	CA-1129000035
	22,05 €	22,05 €	38,85 €	38,85 €	38,85 €	CONSULTAR	CONSULTAR	22,05 €
PROLONGADOR PLÁSTICO	CA-1129000026	CA-1129000026				CA-1129003555		CA-1129000026
	6,30 €	6,30 €				CONSULTAR		6,30 €
PROLONGADOR METÁLICO			CA-1129003553	CA-1129003553	CA-1129003553			
			34,65 €	34,65 €	34,65 €			
BOQUILLA	CA-1129000025	CA-1129000025	CA-1129000012	CA-1129000012	CA-1129000012			CA-1129000025
	4,20 €	4,20 €	3,15 €	3,15 €	3,15 €			4,20 €
CEPILLO MULTIUSO	CA-1129000028	CA-1129000028						
	6,30 €	6,30 €						
SOPORTE CEPILLO			CA-1129000016	CA-1129000016	CA-1129000016			
			11,50 €	11,50 €	11,50 €			
CEPILLO LÍQUIDOS			CA-1129000017	CA-1129000017	CA-1129000017			
			9,45 €	9,45 €	9,45 €			
CEPILLO SUELOS			CA-1129000018	CA-1129000018	CA-1129000018			
			7,35 €	7,35 €	7,35 €			
BOQUILLA DE TAPICERÍA						CA-1129003556	CA-1129003557	
						CONSULTAR	25,00 €	

CA-MB1+11
1,5 HP - 230 V.
160 Lt/min
8 bar
Accesorios incluidos



79,95€

CA-MBL6/1100
1,5 HP - 230 V.
160 Lt/min - 8 bar
Sin aceite
Ref.:CA-1129581037
6 Lt.



119 €

CA-MBL-60
Compresor+enrollador.
1,5 HP - 230 V
160 Lt/min - Sin Aceite
8 Bar 75 dB
2800 r.p.m.
Enrollador de 10 mt

Soporte de pared + Pistola de soplar



199,95 €

CA-MX6-1
1 HP - 230 V.
106 Lt/min
8 bar
59 dB
6 Lt.

Silencioso



149 €

CA-MX24-1
1 HP - 230 V.
106 Lt/min
8 bar
59 dB
24 Lt.

Silencioso



179 €

CA-MB24
2 HP - 230 V.
170 Lt/min
8 bar
24 Lt.



149 €

CA-MB50
2 HP - 230 V.
170 Lt/min
8 bar
50 Lt.



199 €

CA-VCX50

3 HP - 230 V.
350 Lt/min
10 bar
72 dB
50 Lt.



509 €

CA-VCX100

3 HP - 230 V.
350 Lt/min
10 bar
74 dB
100 Lt.



515 €

CA-VCX150/3M

3 HP
380/230 V.
350 Lt/min
10 bar
74 dB
150 Lt.



619 €

CA-VCX150/3T

3 HP
400 V.
350 Lt/min
10 bar
74 dB
150 Lt.



659 €

CA-MCX300/514

5,5 HP - 380 V.
443 Lt/min
75 dB
270 Lt.

14 Bar



1.599 €

CA-MCX300/598

5,5 HP - 380 V.
600 Lt/min - 10 bar
75 dB
270 Lt.



1.349 €

46

CA-MCX500/808

7,5 HP - 380 V.
808 Lt/min - 10 bar
75 dB
500 Lt.



1.730 €

CA-MCX500/998

10 HP - 380 V.
Estrella Triángulo
1.070 Lt/min - 10 bar
78 dB
500 Lt.



2.546 €

CA-MCX500/814

7,5 HP - 380 V.
561 Lt/min
75 dB
500 lt.

14 Bar



2.332 €

CA-MCX500/1014

10 HP - 380 V.
Estrella Triángulo
831 Lt/min
78 dB
500 lt.

14 Bar



2.999 €

CA-MUX360/100

5 HP
598 Lt/min
10 bar

Motor gasolina

HONDA
GP160



1.131,90 €

CA-MUX515/200

5,5 HP
515 Lt/min
10 bar

Motor gasolina

HONDA
GX160



1.533 €

CA-MUX598/300

9 HP - HONDA GX270
600 Lt/min
10 bar

Motor gasolina

HONDA
GX270



2.189,25 €

Auto-regulación de la aceleración

Arranque fácil

Ruedas de goma

Motor Honda

Ergonómico

Rueda pivotante



COMPRESORES INSONORIZADOS DE PISTÓN



CA-MCX598N

5,5 HP - 400 V.
600 l/min
10 bar. 68 dB



2.264€

CA-MCX958N

7,5 HP - 400 V.
830 l/min
10 bar. 66 dB



2.460€

CA-MCX998N

10 HP - 400 V.
1.070 l/min
10 bar. 66 dB



2.760€

CA-MCX598/300N

5,5 HP - 400 V.
598 l/min
10 bar. 68 dB
270 Lt.

Con caldera



2.725€

CA-MCX958/500N

7,5 HP - 400 V.
830 l/min
10 bar. 66 dB
500 Lt.

Con caldera



3.475€

CA-MCX998/500N

10 HP - 400 V.
1070 l/min
10 bar. 66 dB
500 Lt.

Con caldera



3.775€

CA-MCXD598/300N

5,5 HP - 400 V.
598 l/min
10 bar. 68 dB
270 Lt.

Con caldera
y secador



3.999€

CA-MCXD958/500N

7,5 HP - 400 V.
830 l/min
10 bar. 66 dB
500 Lt.

Con caldera
y secador



4.848€

CA-MCXD998/500N

10 HP - 400 V.
1070 l/min
10 bar. 66 dB
500 Lt.

Con caldera
y secador



5.140€

CA-1126000428

Kit de 66 piezas neumática.



142,22 €

CA-1126000738

Enrollador automático 10 m. Carcasa de metal Ø 12 - 8 mm.



97,65 €

CAKITMICHELIN

Kit de aire profesional: Pistola de soplar, pistola de petroleo, pistola de pintar, pistola de hinchar y espiral.



35,28 €

CA-1126001367

Pistola neumática de grasa. Cartucho de 310 ml. Acople 1/4. 250-300 lt/min. Tubo con cuatro salidas. 4-6 Bar. C.F.M. 4 87 PSI.

Usar con lubricador 037



41,90 €

CA-1126001369

Llave criquet. Acople 1/4. Par de apriete 61 Nm. Tuerca M10. 120-160 lt/min. 6 Bar. C.F.M. 4. 87 PSI.

Usar con lubricador 037



83,79 €

CA-1126001363

Martillo cincelador. 170 lt/min. 6 Bar.

Usar con lubricador 037



24,15 €

CA-1126000745

Lijadora roto orbital 170 lt/min. 6 Bar. Disco Ø125 mm 10.000 osc/min. 87 PSI.

Usar con lubricador 037
Con disco de velcro



93,71 €

CA-1126000742

Lijadora roto orbital. 250 lt/min. 6 Bar. Disco Ø150 mm. 10.000 osc/min 87 PSI.

Usar con lubricador 037



60,64 €

CA-1126001368

Pistola de silicona. Acople de 1/4". 170 lt/min. 6 Bar. Cartuchos: 310 ml. 87 PSI.

Usar con lubricador 037



49,61 €

REFERENCIA	DESCRIPCIÓN	OFERTA	REFERENCIA	DESCRIPCIÓN	OFERTA
CA-1126001508	Enchufe rápido universal para manguera de PVC y Poliuretano Ø 6mm	6,62 €	CA-1126001488	Tuerca fresada	6,04 €
CA-1126001509	Enchufe rápido universal para manguera de PVC y Poliuretano Ø 8mm	6,62 €	CA-1126001500	Conexión rápida para manguera Diam. 6 mm	3,31 €
CA-1126001512	Enchufe rápido universal rosca hembra 1/4"	6,62 €	CA-1126001501	Conexión rápida para manguera Diam. 8 mm	3,31 €
CA-1126001513	Enchufe rápido universal rosca hembra 3/8"	6,62 €	CA-1126001503	Conector rápido con cierre bayoneta.	4,41 €
CA-1126001511	Enchufe rápido universal rosca hembra 1/2"	6,62 €	CA-1126001504	Conector rápido rosca hembra. 1/4"	3,31 €
CA-1126001515	Enchufe rápido universal rosca macho 1/4"	5,51 €	CA-1126001505	Conector rápido rosca hembra. 3/8"	3,31 €
CA-1126001516	Enchufe rápido universal rosca macho 3/8"	5,51 €	CA-1126001506	Conector rápido rosca macho. 1/4"	3,94 €
CA-1126001475	Racor en Y hembra 1/4	6,04 €	CA-1126001507	Conector rápido rosca macho. 3/8"	3,94 €
CA-1126001476	Racor en Y macho 1/4 hembra 1/4	3,94 €	CA-1126001518	Purgador de 1/4	4,41 €
CA-1126001477	Racor en T hembra 1/4	5,51 €	CA-1126001520	Llave de paso macho - hembra 1/4	11,03 €
CA-1126001481	Reductor macho hembra 3/8 - 1/4	3,31 €	CA-1126001521	Llave de paso macho - hembra 3/8	11,03 €
CA-1126001478	Reductor macho hembra 1/2 - 1/4	3,31 €	CA-1126001522	Llave de paso macho 1/4"	7,14 €
CA-1126001480	Reductor macho hembra 1/2 - 3/8	3,31 €	CA-1126001527	Válvula de seguridad 1/4	6,93 €
CA-1126001483	Manguito rosca hembra 1/4-1/4	4,41 €	CA-1126001529	Manómetro diam. 50 16 Bar. Rosca posterior	12,13 €
CA-1126001484	Racor macho 1/4 - 1/4	3,31 €	CA-1126001358	Presostato con válvula de arranque. 4x1/4" Hembra	17,64 €
CA-1126001485	Racor macho 3/8 - 3/8	4,41 €			

REFERENCIA	DESCRIPCIÓN	OFERTA	REFERENCIA	DESCRIPCIÓN	OFERTA
CA-1126001361	 Mini lubricador	7,72 €	CA-1126001406	 Pistola de arenar con depósito inferior 1 lt.	29,77 €
CA-1126001433	 Filtro purificador 1/4	34,18 €	CA-6218500004	 Pistola de pintar con depósito inferior y cierre bayoneta. 1 lt. Ø Boquilla 1,5	33,02 €
CA-1126001434	 Lubricador 1/4	39,69 €	CA-1126001422	 Pistola de pintar con depósito superior. 0,5 lt. Ø Boquilla 1,5	33,02 €
CA-1126001435	 Regulador de presión con manómetro. Dos salidas. 180l/min. 12bar 3/8"	41,90 €	CA-1126001423	 Pistola de pintar Prof. Depósito inferior. Cierre abrazaderas. 1 lt. Ø Boquilla 1,5. HVLP	87,10 €
CA-1126001436	 Regulador de presión con manómetro salida universal . 180 l/min. 12bar. 1/4"	19,85 €	CA-1126001426	 Pistola de pintar profesional con depósito superior. 0,5 lt. Ø Boquilla 1,5. HVLP	87,10 €
CA-1126001470	 Boquilla para inflado de neumáticos.	4,41 €	CA-1120009006	 Kit completo paso de fluido. Ø Boquilla 1,5 mm. Para mod. 1855- 1856	12,13 €
CA-1126001472	 Kit 3 boquillas de inflado	5,78 €	CA-1126001051	 Espiral completa con acople universal 5 mt. Diam. 6x8	14,33 €
CA-1126001055	 Pistola de soplar standard	7,72 €	CA-1126001395	 Espiral completa con acople universal 10 mt. Diam. 6x8	16,54 €
CA-1126001399	 Pistola de soplar con boquilla curva de plástico	9,92 €	CA-1126001387	 Manguera PVC 10 mt. con acoples universales. Ø 8x12mm. 20 bar.	24,26 €
CA-1126001400	 Pistola de soplar con boquilla larga	9,92 €	CA-1126001390	 Manguera PVC 20 mt. con acoples universales. Ø 8x12mm. 20 bar.	33,08 €
CA-1126001065	 Inflador de neumáticos 0-12 bar	17,64 €			
CA-1126001404	 Aspirador	29,77 €			
CA-1126001079	 Pistola de petroleo	25,36 €			

COMPRESOR



MODELO	Volt/Hz/Ph	dB	LT./MIN	CFM	m ³ /h	BAR/Psi	HP	KW	KG	AXBXC (cm)	OFERTA
CA-RSX5,5	400/50/3	65	450	15,9	27	10/145	5,5	4	138	84,6x57,2x75	3.699 €
CA-RSX7,5	400/50/3	66	720	25,5	43,2	10/145	7,5	5,5	143	84,6x57,2x75	3.799 €
CA-RSX10	400/50/3	67	860	30,4	51,6	10/145	10	7,5	148	90x70x92	3.899 €
CA-RSX15	400/50/3	65	1430	50,5	85,8	10/145	15	11	270	82x54x75,9	4.999 €
CA-RSX20	400/50/3	67	1900	67,1	114	10/145	20	15	280	94x63x85	5.275 €
CA-RSX25	400/50/3	73	2500	88,4	150	10/145	25	18,5	468	100,5x88,4x118	8.790 €
CA-RSX30	400/50/3	74	2970	105	178,2	10/145	30	22	498	100,5x88,4x118	8.945 €
CA-RSX40	400/50/3	74	3900	137,9	234	10	40	40	679	89x120x135	CONSULTAR
CA-RSX50	400/50/3	75	5000	176,8	300	10	50	50	700	89x120x135	CONSULTAR
CA-RSX75	400/50/3	74	7900	279,3	474	10	75	55	1.230	128,5x168x164	CONSULTAR

Todos los compresores son trifásicos.

COMPRESOR CON SECADOR



MODELO	Volt/Hz/Ph	dB	LT./MIN	CFM	m ³ /h	BAR/Psi	HP	KW	KG	AXBXC	OFERTA
CA-RSXD5,5	400/50/3	65	450	15,9	27	10/145	5,5	4	160	90x70x92	CONSULTAR
CA-RSXD7,5	400/50/3	66	720	25,5	43,2	10/145	7,5	5,5	165	90x70x92	CONSULTAR
CA-RSXD10	400/50/3	67	860	30,4	51,6	10/145	10	7,5	175	90x70x92	CONSULTAR
CA-RSXD15	400/50/3	65	1430	50,5	85,8	10/145	15	11	270	118x76x100	CONSULTAR
CA-RSXD20	400/50/3	67	1900	67,1	114	10/145	20	15	280	89x76x135	CONSULTAR
CA-RSXD25	400/50/3	73	2500	88,4	150	10/145	25	18,5	468	100,5x88,4x118	CONSULTAR
CA-RSXD30	400/50/3	74	2970	105	178,2	10/145	30	22	498	100,5x88,4x118	CONSULTAR

COMPRESOR CON CALDERA

Cabina insonorizada

Manómetro tanque

Panel de Control

Botón de parada de emergencia

Drenaje condensación

Tanque con soportes elevadores



MODELO	Volt/Hz/Ph	LITROS	dB	LT./MIN	CFM	m ³ /h	BAR/Psi	HP	KW	KG	AXBXC	OFERTA
CA-RSX3/90	230/50/1	90	59	300	10,6	18	9/130	3	2,2	84	110x52x125	CONSULTAR
CA-RSX3/90TR	380/50/3	90	59	300	10,6	18	9/130	3	2,2	135	100x52x125	CONSULTAR
CA-RSX5,5/300	400/50/3	270	65	450	15,9	27	10/145	5,5	4	205	163,1x57,2x127,4	4.099 €
CA-RSX7,5/500	400/50/3	500	66	720	25,5	43,2	10/145	7,5	5,5	255	203,8x60x136,7	4.482 €
CA-RSX10/500	400/50/3	500	67	860	30,4	51,6	10/145	10	7,5	260	203,8x60x136,7	4.566 €
CA-RSX15/500	400/50/3	500	65	1430	50,5	85,8	10/145	15	11	349	203,8x70x144,6	5.729 €
CA-RSX20/500	400/50/3	500	67	1900	67,1	114	10/145	20	15	392	203,8x70x144,6	5.909 €
CA-RSX25/500	400/50/3	500	73	2500	88,4	150	10/145	25	18,5	670	203,8x88,4x179	CONSULTAR
CA-RSX30/500	400/50/3	500	74	2970	105	178,2	10/145	30	22	700	203,8x88,4x179	CONSULTAR

COMPRESOR CON SECADOR Y CALDERA

Cabina insonorizada

Drenaje condensación

Panel de Control

Botón de parada de emergencia



MODELO	Volt/Hz/Ph	LITROS	dB	LT./MIN	CFM	m ³ /h	BAR/Psi	HP	KW	KG	AXBXC	OFERTA
CA-RSXD5,5/300	400/50/3	270	65	450	15,9	27	10/145	5,5	4	245	163,1x57,2x127,4	5.336 €
CA-RSXD7,5/500	400/50/3	500	66	720	25,5	43,2	10/145	7,5	5,5	295	163,1x57,2x127,4	5.499 €
CA-RSXD10/500	400/50/3	500	67	860	30,4	51,6	10/145	10	7,5	300	203,8x60x136,7	5.599 €
CA-RSXD15/500	400/50/3	500	65	1430	50,5	85,8	10/145	15	11	390	203,8x70x144,6	6.899 €
CA-RSXD20/500	400/50/3	500	67	1900	67,1	114	10/145	20	15	438	203,8x70x144,6	6.950 €
CA-RSXD25/500	400/50/3	500	73	2500	88,4	150	10/145	25	18,5	670	203,8x88,4x179	CONSULTAR
CA-RSXD30/500	400/50/3	500	74	2970	105	178,2	10/145	30	22	700	203,8x88,4x179	CONSULTAR

SECADORES FRIGORÍFICOS TDRY

MODELO	CÓDIGO	LT./MIN	CFM	m ³ /h	MBAR	BSP	C° L	LxPxH cm.	KG	OFERTA
CA-TDRY4	4102002780	350	12	21	0,15	3/4" M	4	350x493x450	19	799 €
CA-TDRY6	4102002781	600	21	36	0,25	3/4" M	4	350x493x450	19	899 €
CA-TDRY9	4102002782	850	30	51	0,25	3/4" M	4	350x493x450	20	1.039 €
CA-TDRY12	4102002783	1200	42	72	0,25	3/4" M	4	350x493x450	25	1.099 €
CA-TDRY18	4102002784	1825	64	110	0,30	3/4" M	4	350x493x450	27	1.299 €
CA-TDRY24	4102003277	2350	83	141	0,32	1"	4	370x498x764	44	1.375 €
CA-TDRY30	4102003278	3000	106	180	0,38	1"	4	370x498x764	44	1.770 €



CALDERAS VERTICALES LT

- Equipado con válvula de seguridad CE.
- Válvula manual de drenaje de condensado.
- Manómetro
- Salida de aire

MODELO	CÓDIGO	LITROS	Ø	BAR	PSI	ØXAlto (mm.)	OFERTA
CA-LT270CE	1121710100	270	3/4"	11	160	540x1950	409 €
CA-LT500CE	1121710101	500	3/4"	11	160	666x2160	719 €
CA-LT720CE	1121710102	720	3/4"	11	160	800x2070	999 €
CA-LT900CE	1121710124	900	1"	11	160	800x2115	1.150 €



FILTROS

FQ 1000 ÷ 40000 (3 µ) 3 MICRAS.

MODELO	CÓDIGO	LT./MIN	CFM	m ₃ /h	BSP	OFERTA
CA-FQ1000*	1127210250	1000	35,34	60	3/8"	119 €
CA-FQ1300*	1127210093	1300	45,94	78	1/2"	129 €
CA-FQ2000*	1127210096	2000	70,67	120	3/4"	145 €
CA-FQ3300*	1127210098	3300	116,61	198	1"	185 €
CA-FQ5600*	1127210254	5600	197,88	335	1"	209 €
CA-FQ8500*	1127210255	8500	300,35	510	1-1/2"	239 €
CA-FQ13000*	1127210256	13000	459,36	780	1-1/2"	285 €

* Equipado con drenaje manual SC y manómetro diferencial MDM60

Líquido
Polvo



FP 1000 ÷ 40000 (1 µ - 0,1 mg/m³)

LÍQUIDO/POLVO 0,1 MICRA ACEITE 0,1 mg/m³

MODELO	CÓDIGO	LT./MIN	CFM	m ₃ /h	BSP	OFERTA
CA-FP1000*	1127210259	1000	35,34	60	3/8"	119 €
CA-FP1300*	1127210106	1300	45,94	78	1/2"	129 €
CA-FP2000*	1127210108	2000	70,67	120	3/4"	145 €
CA-FP3300*	1127210110	3300	116,61	198	1"	185 €
CA-FP5600*	1127210263	5600	197,88	335	1"	200 €
CA-FP8500*	1127210264	8500	300,35	510	1-1/2"	239 €
CA-FP13000*	1127210265	13000	459,36	780	1-1/2"	285 €

* Equipado con drenaje manual SC y manómetro diferencial MDM60

Líquido
Polvo
Aceite



FD 1000 ÷ 40000 (0,01 µ - 0,01 mg/m³)

LÍQUIDO/POLVO 0,01 MICRA. ACEITE 0,01 mg/m³

MODELO	CÓDIGO	LT./MIN	CFM	m ₃ /h	BSP	OFERTA
CA-FD1000*	1127210268	1000	35,34	60	3/8"	119 €
CA-FD1300*	1127210124	1300	45,94	78	1/2"	129 €
CA-FD2000*	1127210127	2000	70,67	120	3/4"	145 €
CA-FD3300*	1127210129	3300	116,61	198	1"	185 €
CA-FD5600*	1127210272	5600	197,88	335	1"	209 €
CA-FD8500*	1127210273	8500	300,35	510	1-1/2"	239 €
CA-FD13000*	1127210274	13000	459,36	780	1-1/2"	285 €

* Equipado con drenaje manual SC y manómetro diferencial MDM60

Líquido
Polvo
Aceite



FILTROS

FC 1000 ÷ 40000 (0,003 μ)

Aceite

MODELO	CÓDIGO	LT./MIN	CFM	m ³ /h	BSP	OFERTA
CA-FC1000*	1127210277	1000	35,34	60	3/8"	119 €
CA-FC1300*	1127210139	1300	45,94	78	1/2"	129 €
CA-FC2000*	1127210142	2000	70,67	120	3/4"	145 €
CA-FC3300*	1127210146	3300	116,61	198	1"	185 €
CA-FC5600*	1127210281	5600	197,88	335	1"	209 €
CA-FC8500*	1127210282	8500	300,35	510	1-1/2"	239 €
CA-FC13000*	1127210283	13000	459,36	780	1-1/2"	285 €



* Equipado con drenaje manual SC y manómetro diferencial MDM60

FQ+FP+FD

Especial taller

MODELO	CÓDIGO	LT./MIN	CFM	m ³ /h	BSP	OFERTA
3F-1300	1127210703	1300	45,94	78	1/2"	CONSULTAR
3F-2000	1127210704	2000	70,67	120	3/4"	
3F-5600	1127210705	5600	197,88	335	1"	



FQ+FP+FD+FC

Especial carrocería

MODELO	CÓDIGO	LT./MIN	CFM	m ³ /h	BSP	OFERTA
4F-1300	1127210706	1300	45,94	78	1/2"	CONSULTAR
4F-2000	1127210707	2000	70,67	120	3/4"	
4F-5600	1127210708	5600	197,88	335	1"	



PURGADOR AUTOMÁTICO AIRTEC 1/2"

CA1127560559

Para compresor de tornillo

Programable



315 €

PURGADOR AUTOMÁTICO AIRTEC 1/8"

CA1127560108

Para compresor de correas.

Con caldera



135 €

MPX16E

125 Bar
120 lt/h.
1600 W.
230V./50 Hz.
HI-14749



109€

MPX19EH

140 Bar
460 lt/h.
1900 W.
230V./50 Hz.
HI-14651



169€

MPX25EHDS

170 Bar
500 lt/h.
2500 W.
230V./50 Hz.
HI-14752



2 velocidades

209€

MPX22EHX

160 Bar
450 lt/h.
2200 W.
230V./50 Hz.
HI-14654



Inducción

265€

MPX25DTS

150 Bar
810 lt/h.
2500 W.
230V./50 Hz.
HI-15052



**Sistema DTS
patentado
2 Bombas**

278€

MPX27DTS

160 Bar
850 lt/h.
2700 W.
230V./50 Hz.
HI-15053



**Sistema DTS
patentado
2 Bombas**

299€

MPX160CK

160 Bar
510 lt/h.
2900 W.
230 V.
HI-14524



**Enrollador
no incluido
opcional**



599€

ACC. ROTATIVA
Ref.: 40151
P.V.P.: 40 €

HI-MPX150HDC

150 Bar - 630 lt/h.
3000 W.
230V. /50 Hz.
1.450 r.p.m.



**Enrollador
no incluido
opcional**

999€

ACC. ROTATIVA
Ref.: 41503
P.V.P.: 93 €

HI-MPX170HDC

170 Bar
780 lt/h.
5000 W.
400V. /50 Hz.



Enrollador no
incluido opcional
Trifásica

1.150€

ACC. ROTATIVA
Ref.: 41503
P.V.P.: 93 €

HI-MPX200HDK

200 Bar
900 lt/h.
7400 W.
400V. /50 Hz.



Enrollador no
incluido opcional
Trifásica

1.395€

ACC. ROTATIVA
Ref.: 41503
P.V.P.: 93 €

MPX210TL

207 Bar
570 lt/h.
5 HP
HI-26837



Motor Loncin
Gasolina

460€

ACC. ROTATIVA
Ref.: 46235
P.V.P.: 45 €

MPX210THD

210 Bar
690 lt/h.
5,5 HP
HI-27148



Motor Honda
Gasolina

819€

ACC. ROTATIVA
Ref.: 46149
P.V.P.: 45 €

AR-1490

280 Bar
960 lt/h.
13 HP
HI-26408



Motor Honda
Gasolina

2.350€

ACC. ROTATIVA
Ref.: 40964
P.V.P.: 67 €

HI-MPX140HL

140 Bar
480 lt/h.
2400 W.
230V. /50 Hz.



Agua caliente

1.250€

HI-MPX170HP

170 Bar
780 lt/h.
5000 W.
400V. /50 Hz.



Agua caliente
Trifásica

2.550€

HI-MPX200HD

200 Bar
900 lt/h.
7400 W.
400V. /50 Hz.



Agua caliente
Trifásica

3.400€

ARTÍCULO	REF.	MODELO DE MÁQUINA														OFERTA	
		MPX 14E	MPX 16E	MPX 17EH	MPX 19EH	MPX 22EH	MPX 25EH	MPX 17EHDS	MPX 19EHDS	MPX 22EHDS	MPX 25EHDS	MPX 20EHX	MPX 22EHX	DTS25	DTS27		
PISTOLA	HI-46160	S	S														14,70 €
PISTOLA	HI-46161			S	S	S	S	S	S	S	S	S	S	S	S	S	16,80 €
EXTENSIÓN LANZA	HI-46163	S	S														8,40 €
EXTENSIÓN LANZA	HI-46162			S	S	S	S	S	S	S	S	S	S	S	S	S	10,19 €
BOQUILLA REGULABLE	HI-46165	S															7,25 €
BOQUILLA REGULABLE	HI-46166		S									S					7,25 €
BOQUILLA REGULABLE	HI-46167			S	S			S	S								7,25 €
BOQUILLA REGULABLE	HI-46168					S				S							7,25 €
BOQUILLA REGULABLE	HI-46169						S				S						7,25 €
BOQUILLA REGULABLE	HI-46170	Descatalogada. Sustituida por ref. (HI-46167)											S		7,25 €		
BOQUILLA REGULABLE (2 UDS.)	HI-46656												S	S			15,23 €
BOQUILA TURBO	HI-46164	S	S	S	S	S	S	S	S	S	S	S	S				7,25 €
BOQUILLA TURBO	HI-46655												S	S			15,75 €
PORTABOQUILLA DOBLE	HI-46654												S	S			16,80 €
MANGUERA	HI-46172	S															13,65 €
MANGUERA	HI-46173		S														20,90 €
MANGUERA	HI-46174			S	S	S		S	S	S							22,64 €
MANGUERA	HI-46175					S					S	S	S				25,25 €
MANGUERA	HI-46657												S	S			26,25 €
PROLONGACIÓN 8MT	HI-46189	0	0	0	0	0	0	0	0	0	0	0	0	0	0	0	26,50 €
PROLONGACIÓN 8MT	HI-46658													0	0		39,90 €
KIT DE DETERGENTE	HI-46176	S	S	S	S	S	S	S	S	S	S	S	S				8,40 €
KIT DETERGENTE ALTA PRESIÓN	HI-46222	0	0	0	0	0	0	0	0	0	0	0	0				9,45 €
BOQUILLA DE ÁNGULOS 5 POSICIONES	HI-46230	0											0				26,25 €
BOQUILLA DE ÁNGULOS 5 POSICIONES	HI-46231		0									0					26,25 €
BOQUILLA DE ÁNGULOS 5 POSICIONES	HI-46232			0	0			0	0								26,25 €
BOQUILLA DE ÁNGULOS 5 POSICIONES	HI-46233					0				0							26,25 €
BOQUILLA DE ÁNGULOS 5 POSICIONES	HI-46234						0				0						26,25 €
BOQUILLA DE ÁNGULOS 5 POSICIONES	HI-46660												0	S			34,65 €

S = De serie
0 = Opcional

ARTÍCULO	REF.	MODELO DE MÁQUINA														OFERTA
		MPX 14E	MPX 16E	MPX 17EH	MPX 19EH	MPX 22EH	MPX 25EH	MPX 17EHDS	MPX 19EHDS	MPX 22EHDS	MPX 25EHDS	MPX 20EHX	MPX 22EHX	DTS25	DTS27	
LANZA MULTIFUCIÓN	HI-46225	0											0			15,75 €
LANZA MULTIFUCIÓN	HI-46226		0										0			15,75 €
LANZA MULTIFUCIÓN	HI-46227			0	0			0	0							15,75 €
LANZA MULTIFUCIÓN	HI-46228					0				0						15,75 €
LANZA MULTIFUCIÓN	HI-46229						0				0					15,75 €
KIT DESATASCO TUBERÍA 8 MT	HI-46190	0	0	0	0	0	0	0	0	0	0	0	0			15,75 €
KIT DESATASCO TUBERÍA 16 MT	HI-46191													0	0	18,90 €
CEPILLO	HI-46177	0	0	0	0	0	0	0	0	0	0	0	0	0	0	14,70 €
CEPILLO	HI-46178	0	0	0	0	0	0	0	0	0	0	0	0	0	0	6,30 €
CEPILLO ROTATIVO	HI-46179	0	0	0	0	0	0	0	0	0	0	0	0	0	0	19,95 €
CEPILLO DE SUELO 25 CM	HI-46196	0	0	0	0	0	0	0	0	0	0	0				61,95 €
CEPILLO SUELO CON REGULACIÓN 30 CM	HI-46197	0	0	0	0	0	0	0	0	0	0	0				75,60 €
KIT DE ARENA	HI-46180	0	0	0	0	0	0	0	0	0	0	0				88,20 €
KIT DE SUCCIÓN DE AGUA	HI-46181	0	0	0	0	0	0	0	0	0	0	0	0	0	0	61,95 €
ADAPTADOR DE BOQUILLAS	HI-46171	0	0	0	0	0	0	0	0	0	0	0	0	0	0	6,83 €
KIT EXTENSIÓN LANZA DE 1.6 MT	HI-46188	0	0	0	0	0	0	0	0	0	0	0	0	0	0	61,95 €
ADAPTADORES	HI-46184	0	0	0	0	0	0	0	0	0	0	0	0	0	0	14,37 €
KIT DE ADAPTADORES	HI-46224	0	0	0	0	0	0	0	0	0	0	0	0	0	0	17,41 €
FILTRO (3 UDS)	HI-46185	S	S	S	S	S	S	S	S	S	S	S	S	S	S	13,06 €
KIT FILTRO DE AGUA	HI-46186	0	0	0	0	0	0	0	0	0	0	0	0	0	0	12,19 €
ENCHUFE RÁPIDO	HI-46187	0	0	0	0	0	0	0	0	0	0	0	0	0	0	8,27 €

S = De serie

0 = Opcional

ARTÍCULO	REF.	MODELO DE MÁQUINA						OFERTA
		AR-1490	MPX210TH0	MPX210TL	MPX150HDC	MPX170HDC	MPX200HDK	
PISTOLA	HI-43524	S						CONSULTAR
PISTOLA	HI-43525		S					25,17 €
PISTOLA	HI-40925			S	S	S	S	59,00 €
PISTOLA	HI-41045							39,00 €
PISTOLA	HI-41046							39,00 €
MANGUERA	HI-1700980	S						89,56 €
MANGUERA	HI-3780493		S	S				40,63 €
MANGUERA	HI-1271960				S	S		128,00 €
MANGUERA	HI-1700980						S	89,56 €
LANZA	HI-3600650		S	S				35,00 €
LANZA	HI-3600340	S			S	S	S	27,00 €
BOQUILLA BAJA PRESIÓN	HI-3600400	S	S	S	S	S	S	10,00 €
BOQUILLA 15°	HI-3600360	S			S			10,00 €
BOQUILLA 25°	HI-3600370	S			S			10,00 €
BOQUILLA 40°	HI-3600380	S			S			10,00 €
BOQUILLA 15°	HI-3600490	S			S	S	S	10,00 €
BOQUILLA 25°	HI-3600500	S			S	S	S	10,00 €
BOQUILLA 40	HI-3600510	S			S	S	S	10,00 €
BOQUILLA 0°	HI-3600930		S	S				10,00 €
BOQUILLA 15°	HI-3600940		S	S				10,00 €
BOQUILLA 25°	HI-3600960		S	S				10,00 €
CEPILLO	HI-46177	0	0	0	0	0	0	14,70 €
SUCCIÓN AGUA (46181)	HI-41592	0	0	0	0	0	0	61,95 €
PATIO CLEANER 36CM	HI-46239	0	0	0	0	0	0	136,50 €
KIT DESATASCO TUBERÍA 8 MT	HI-46190	0	0	0	0	0	0	15,75 €
KIT DESATASCO TUBERÍA 16 MT	HI-46191	0	0	0	0	0	0	18,90 €

S = De serie

0 = Opcional

FM-TR076

Disco Ø210 mm. 1200 W.
Motor universal

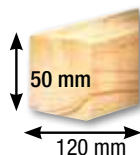

179€

FM-TR230

Disco Ø255 mm. 1600 W.
Motor universal

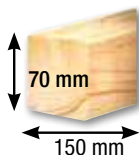

229€

FM-TR235

Disco Ø250 mm. 1800 W.
Motor universal

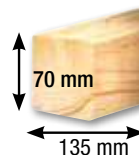

259€

FM-TR240

Disco Ø254 mm. 1450 W.
Motor universal

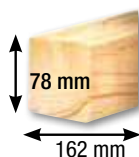

329€



FM-TR090

Disco Ø305 mm. 2000 W.
Motor universal

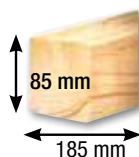

379€

62

FM-TR1021

Disco Ø210 mm. 1500 W.
Motor universal

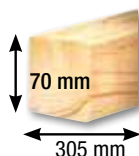

229€



FM-TR1025DB

Disco Ø255 mm. 2000 W.
Motor universal. Doble inclinación

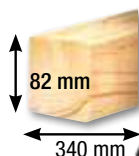

349€



FM-TR1030DB

Disco Ø305 mm. 2000 W.
Motor universal. Doble inclinación

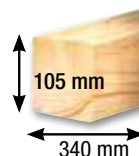

429€



FM-999EVO

Disco Ø305 mm. 1.700 W.
Motor universal

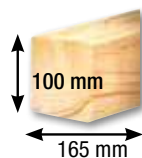

799€

FM-1050/3D

Disco Ø305 mm.
1.800 W.
Motor universal
Telescópica

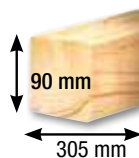

739€

FM28-182

250 W.-230V.
Cinta:
1.400x6x0,35-Z6

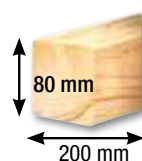

169€

FM28-186

420 W.-230V.
Cinta:
1.790x10x0,35-Z6

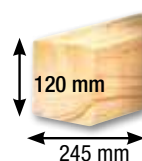

289€

FM28-191

750 W.-230V.
Cinta:
2.240x12,5x0,5



499€

63

FM-VB28-194

1100 W.-230V.
Cinta:
2.560x10x0,5

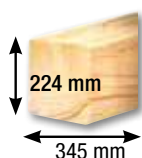

1,099€

FM28-195

2200 W.-230V.
Cinta:
3.607x25x0,6-Z3

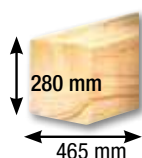

2,100€

FM-PF250

Máquina combinada. 1500 W.
Ancho cepillado: 254 mm.
Alto regreuso de: 5 a 120 mm.
Cuchillas:
261x16,5 mm.
Ref.: F22-573
P.V.P.: 44 €



429€

FM-CYCLONE

Cepilladora regruesadora
1.500 W.



Cuchillas 210x20x1,6 mm.
Ref.: FM3280010 P.V.P.: 32 €

479€

FM-330SMARTY

Banco plegable.

Carga 100 Kg. max.

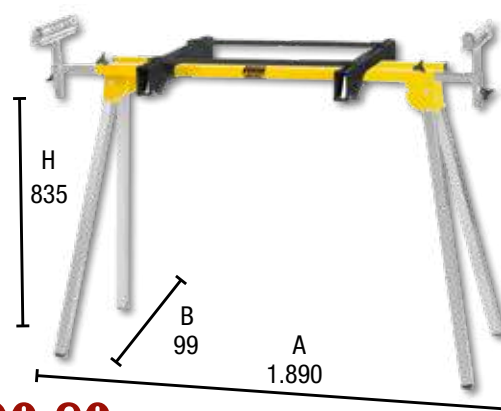

109,89€

BD31-462

Lijadora combinada. 370 W.
ø Disco de lija 150 mm.
autoadhesivo.
Banda de lija 100x914mm.



219€

SH23-730

Afiladora 150 W.
Muela 200x40x12 mm.
Disco 200x300x12



175€

SS40-562

Sierra para marquetería
125 W.
Hoja de sierra
127 mm.

LED



229€

FM-IB500

Encoladora de cantos. 2.000 W.
Flujo de calor 18 - 30 m³/h
350° - 500° °C

2 velocidades
Guía ajustable

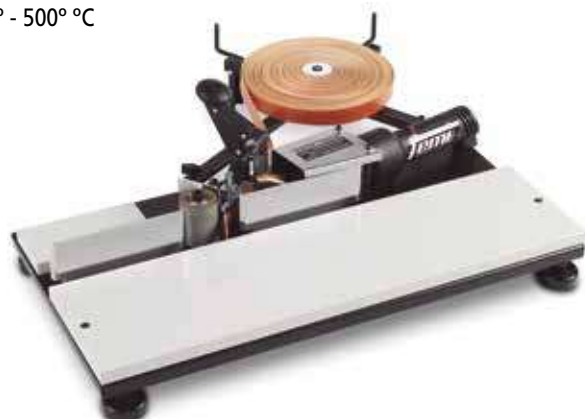

578€

CS20-140

Tronzadora metal
Disco Ø355 mm.
2.000 W.
3.000 r.p.m.

Metal



169€

Aspiradores versátiles y manejables para operaciones de aspiración de serrín. Adaptación para el acoplamiento con máquinas de carpintería. Silenciosos motores de inducción potentes y fiables con protección térmica de seguridad. Filtración 35 microns. Ventilador de aspiración de aluminio. Bases con ruedas giratorias para el transporte. Se suministran en Kit de montaje.

FM-DC350PLUS

900 W.
950 m³/h
Ø boquilla para tubo aspiración: 100x1
Presión: 175 mm. H₂O

- Tubo flexible longitud 2 m.
- Boquilla para pavimentos
- Bolsa de recogida de polvo nylon
- Bolsa filtrante en hebrado (5µm) para virutas

Monofásico



339€

FM-DC351PLUS

1.500 W.
2.700 m³/h
Ø boquilla para tubo aspiración: 100x2
Presión: 196 mm. H₂O

- Tubo flexible longitud 2 m.
- Bolsa de recogida de polvo nylon
- Bolsa filtrante en hebrado (5µm) para virutas

Monofásico



499€

FM-DC352PLUS

1.500 W.
2.700 m³/h
Ø boquilla para tubo aspiración: 100x2
Presión: 196 mm. H₂O

- Tubo flexible longitud 2 m.
- Bolsa de recogida de polvo nylon
- Bolsa filtrante en hebrado (5µm) para virutas

Trifásico



499€

FM-DC355PLUS

2.200 W.
3.900 m³/h
Ø boquilla para tubo aspiración: 100x3
Presión: 196 mm. H₂O

- Tubo flexible longitud 2 m.
- Bolsa de recogida de polvo nylon
- Bolsa filtrante en hebrado (5µm) para virutas

Trifásico



599€

FM-780XL

MEDIDA CINTA
(mm/Ø):
1.335x13x0,65
850 W.
2 velocidades



399€

CAPACIDAD DE CORTE			
0°	105x93 mm.	105 mm.	102x102 mm.
45°	70x60 mm.	72 mm.	68x68 mm.

FM-784XL

MEDIDA CINTA
(mm/Ø):
1.440x13x0,65
1.200 W.
Regulación electrónica
"Constant speed"



758€

CAPACIDAD DE CORTE			
0°	120x115 mm.	120 mm.	119x119 mm.
45°	85x70 mm.	85 mm.	80x80 mm.

FM-785XL

MEDIDA CINTA
(mm/Ø):
1.735x13x0,9
1.600 W.
2 velocidades



1.199€

CAPACIDAD DE CORTE			
0°	205x150 mm.	152 mm.	150x150 mm.
45°	105x95 mm.	106 mm.	102x102 mm.

FM-ABS105

MEDIDA CINTA
(mm/Ø):
1.335x13x0,65
950 W.
2 velocidades

Bajada automática



649€

CAPACIDAD DE CORTE			
0°	100x85 mm.	105 mm.	95x95 mm.
45°	65x60 mm.	65 mm.	65x65 mm.

FM-ABSNG120

MEDIDA CINTA
(mm/Ø):
1.440x13x0,65
1.300 W.
Regulación electrónica
"Constant speed"

Bajada automática

MÁS VELOCIDAD
60%
NG
NEW GENERATION



1.049€

CAPACIDAD DE CORTE			
0°	120x102 mm.	120 mm.	112x112 mm.
45°	78x78 mm.	80 mm.	78x78 mm.
60°	50x43 mm.	50 mm.	48x48 mm.

FM-ABSNG160

MEDIDA CINTA
(mm/Ø):
1.735x13x0,9
2.000 W.
Regulación electrónica
"Constant speed"

Bajada automática

MÁS VELOCIDAD
60%
NG
NEW GENERATION



1.699€

CAPACIDAD DE CORTE			
0°	160x140 mm.	150 mm.	150x150 mm.
45°	120x120 mm.	100 mm.	100x100 mm.

FM-2200XL

MEDIDA
CINTA (mm/Ø):
2.140x19x0,9
2.000 W.
Regulación
electrónica
"Constant speed"



CAPACIDAD DE CORTE			
0°	200x75 mm. 190x135 mm.	175 mm.	175x175 mm.
45°	150x110 mm.	110 mm.	110x110 mm.
60°	100x70 mm.	75 mm.	75x75 mm.

1.999€

FM-2200DAXL

MEDIDA
CINTA (mm/Ø):
2.140x19x0,9
2.000 W.
Regulación
electrónica
"Constant speed"



Sistema
hidráulico
de control
de bajada
automática

CAPACIDAD DE CORTE			
0°	200x75 mm. 190x135 mm.	175 mm.	175x175 mm.
45°	150x110 mm.	110 mm.	110x110 mm.
60°	100x70 mm.	75 mm.	75x75 mm.

2.300€

FM-N250DAXL

MEDIDA
CINTA (mm/Ø):
2.480x27x0,9
1.100 W.



Sistema
hidráulico
de control
de bajada
automática
Monofásica

CAPACIDAD DE CORTE			
0°	245x160 mm. 250x110 mm.	225 mm.	185x185 mm.
45°	135x185 mm. 145x150 mm.	150 mm.	145x145 mm.
60°	63x107 mm. 69x90 mm.	70 mm.	70x70 mm.

2.299€

FM-N251DAXL

MEDIDA
CINTA (mm/Ø):
2.480x27x0,9
750/1100 W.
2 velocidades



Sistema
hidráulico
de control
de bajada
automática
Trifásica

CAPACIDAD DE CORTE			
0°	245x160 mm. 250x110 mm.	225 mm.	185x185 mm.
45°	135x185 mm. 145x150 mm.	150 mm.	145x145 mm.
60°	63x107 mm. 69x90 mm.	70 mm.	70x70 mm.

2.299€

FM-N310DA/DG

MEDIDA
CINTA (mm/Ø):
2.750x27x0,9
1.000/1500 W.
2 velocidades

CAPACIDAD DE CORTE			
0°	320x200 mm.	255 mm.	195 mm.
45° IZDA.	210x80 mm.	205 mm.	195 mm.
60°	120x135 mm.	125 mm.	125 mm.
45° DCHA.	170x190 mm.	205 mm.	175 mm.

4.299€



Sistema
hidráulico
de control
de bajada
automática
Trifásica

PROFESIONALES, ECOLÓGICAS E INDUSTRIALES

FM-404

Esmeriladora/pulidora
Motor 370 W.
2.800 r.p.m. ø Muela 150x20x16 mm.

Doble muela



320,79 €

FM-405

Esmeriladora/pulidora
Motor 500 W. 230 V.
2.800 r.p.m. ø Muela 200x20x16 mm.

Doble muela



398,49 €

FM-424

Esmeriladora/pulidora
Motor 370 W. 230 V.
ø Muela 150x20x16 mm.
Ø Cepillo 150x20x16 mm.

Muela/Cepillo



365,19 €

FM-425

Esmeriladora/pulidora
Motor 500 W. 230 V.
ø Muela:
200x20x16 mm.
Ø Cepillo:
150x20x16 mm.

Muela/Cepillo



442,89 €

ESMERILADORAS INDUSTRIALES

REF.	POTENCIA	MUELA	RPM	OFERTA	Doble muela
FM-240M	450 W. - 230 V.	150x20x16	2800	452,39 €	
FM-241M	450 W. - 380 V.	150x20x16	2800	452,39 €	
FM-242M	750 W. - 230 V.	200x25x20	2800	632,20 €	
FM-243M	850 W. - 380 V.	200x25x20	2800	631,59 €	
FM-143MEVO	1100 W. - 380 V.	200x30x20	2800	1.065,10 €	
FM-145MEVO	1500 W. - 230 V.	250x35x25	1400	1.351,43 €	
FM-146M	2200 W. - 230 V.	300x40x20	1400	2.863,21 €	



ESMERILADORAS INDUSTRIALES COMBINADAS

Muela/Cepillo

REF.	POTENCIA	MUELA	CEPILLO	OFERTA
FM-244M	450 W. - 230 V.	150x25x16	150x25x16	548,59 €
FM-245M	450 W. - 380 V.	150x25x16	150x25x16	548,59 €
FM-246M	750 W. - 230 V.	200x25x20	200x25x16	697,48 €
FM-247M	850 W. - 380 V.	200x25x20	200x25x16	697,48 €
FM-163MEVO	1100 W. - 380 V.	200x40x20	200x30x20	1.156,73 €
FM-165MEVO	1500 W. - 380 V.	250x40x25	250x40x20	1.443,06 €
FM-166M	2200 W. - 380 V.	300x40x20	300x60x25	2.886,11 €



PULIDORAS INDUSTRIALES

REF.	POTENCIA	CEPILLO	RPM	OFERTA
FM-213	750 W. - 230 V.	200x25x16	2800	870,41 €
FM-214	850 W. - 380 V.	200x25x16	2800	916,23 €
FM-209EVO	1100 W. - 380 V.	250x40x20	2800	1.294,17 €
FM-211	2200 W. - 380 V.	300x60x25	2800	3.103,71 €



ESMERILADORAS ECOLÓGICAS DE DOBLE MUELA

Doble muela

REF.	POTENCIA	MUELA	RPM	OFERTA
FM-191M	450 W. - 380 V.	150x20x16	2800	1.569,04 €
FM-192M	850 W. - 380 V.	200x25x20	2800	1.717,92 €
FM-193MEVO	1100 W. - 380 V.	200x30x20	2800	2.130,22 €
FM-194MEVO	1500 W. - 380 V.	200x35x25	1400	2.359,26 €
FM-195M	2200 W. - 380 V.	300x40x30	1400	3.905,41 €



ESMERILADORAS COMBINADAS ECOLÓGICAS

Muela/Cepillo

REF.	POTENCIA	CEPILLO	RPM	OFERTA
FM-196M	450 W. - 380 V.	150x20x16	2800	1.740,83 €
FM-197M	850 W. - 380 V.	200x25x20	2800	1.821 €
FM-198MEVO	1100 W. - 380 V.	200x30x20	2800	2.210,39 €
FM-199MEVO	1500 W. - 380 V.	250x35x25	2800	2.473,81 €
FM-200M	2200 W. - 380 V.	300x40x30		4.111,56 €



PROFESIONALES, ECOLÓGICAS E INDUSTRIALES

PULIDORAS ECOLÓGICAS

REF.	POTENCIA	CEPILLO	OFERTA
FM-204	850 W. - 380 V.	200x25x16	1.981,34 €
FM-202EVO	1100 W. - 380 V.	250x40x20	2.393,24 €
FM-203	2200 W. - 380 V.	300x60x30	4.294,81 €



LIJADORAS DE BANDA

Industrial

REF.	POTENCIA	BANDA	RPM	OFERTA
FM-510	600 W. - 380 V.	100x220	2800	1.333,90 €
FM-511	550 W. - 230 V.	100x220	2800	1.333,90 €
FM-542B	1100 W. - 380 V.	120x1500	1400	1.699 €
FM-543B	750 W. - 230 V.	120x1500	1400	1.699 €
FM-504B	600 W. - 900 V.	120x1500	1400/2800	2.100 €
FM-507B	1350-1600 W. - 380 V.	150x1750	1400/2800	3.100 €



LIJADORAS DE BANDA/DISCO

Industrial

REF.	POTENCIA	BANDA mm	MT/SEC	Ø DISCO	OFERTA
FM-525B	1350-1600 W. - 380 V.	-	16	400	2.854,75 €
FM-539B	1350-1600 W. - 380 V.	150x1750	30	400	4.300 €



ESMERILADORAS/LIJADORAS DE BANDA

REF.	POTENCIA (W.)	BANDA	MUELA	RPM	OFERTA
FM-293N	750 W.-230 V.	100x1000	200x25x20	2800	899 €
FM-294N	850 W.-380 V.	100x1000	200x25x20	2800	899 €



69

ESMERILADORAS / LIJADORAS DE BANDA

Industrial

REF.	POTENCIA	BANDA	MUELA	RPM	OFERTA
FM-296EVO	1100 W. - 380 V.	50X2200	200X25X20	2800	2.273,39 €
FM-298EVO	1100 W. - 380 V.	50X2200	-	2800	3.194,58 €



LIJADORAS DE BANDA HORIZONTAL

Industrial

REF.	POTENCIA	BANDA	MT/SEC	SUP LIJA	OFERTA
FM-577	4000 W. - 380 V.	150X2000	15/30	460/180	1.778 €
FM-575	3000 W. - 380 V.	75X2000	30	460x75	1.149 €
FM-574	2200 W. - 230 V.	75X2000	30	460x75	1.149 €



TACO ABRASIVO

Granos fino, medio y grueso.



UNIDAD
0,59€

Pack 5 uds.

MSE-TFINOPACK P.V.P.: 2,69 €

MSE-TMEDIOPACK P.V.P.: 2,69 €

ESPONJA ABRASIVA

Granos fino, medio y grueso.



UNIDAD
0,59€

Pack 5 uds.

MSE-EFINOPACK P.V.P.: 2,69 €

MSE-EMEDIOPACK P.V.P.: 2,69 €

TACO ANGULO ABRASIVO

Granos fino, medio y grueso.



UNIDAD
0,65€

70

PLIEGOS MSE-SIM

Lija para madera, soporte papel, adhesivo cola, abrasivo silice. Granos 40-80-100-150.

Madera



UD. DESDE
0,16€

* Cajas de 50 unidades.

PLIEGOS MSE-CRD

Lija para pared, soporte papel, adhesivo cola, abrasivo óxido de aluminio. Granos 40-80-100-150.

Pared y madera



UD. DESDE
0,35€

* Cajas de 50 unidades.

PLIEGOS MSE-ASS

Lija para pared, soporte papel-latex, adhesivo cola abrasivo corindón + estearato. Granos 80-180-280 320-400.

Pintura y lacas



UD. DESDE
0,35€

* Cajas de 100 unidades.

PLIEGOS MSE-FE

Lija para metal, soporte tela, adhesivo cola abrasivo corindón óxido de aluminio. Granos 40-60-100 220-320.

Metal



UNIDAD
0,41€

* Cajas de 50 unidades.

PLIEGOS MSE-WEC

Lija al agua, soporte papel-latex, adhesivo cola abrasivo corindón + estearato. Granos 180-280-360 500-120-1500-2000.

Al agua

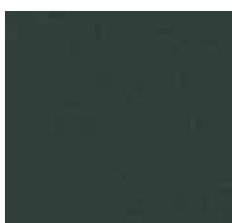

UD. DESDE
0,45€

* Cajas de 100 unidades.

PLIEGOS MSE-IMJ

Pliego de lija, soporte tela abrasiva, extra flexible al corindón, adhesivo doble resina, abrasivo corindón, óxido de aluminio. Granos 60-80-120-180.

Madera dura y metal



UNIDAD
0,67€

* Cajas de 50 unidades.



BLISTERS

Papel abrasivo al Corindón, resina sobre cola, esparcimiento semiabierto. Soporte papel. Para pulir madera basta, barnices sobre madera y metal.

93 x 230 mm.

Lote 10 lijas.
8 agujeros.



REFERENCIA	GRANO	OFERTA
IMP3128	50	2,65 €
IMP3129	80	
IMP3130	120	
IMP3131	180	

115 x 280 mm.

Lote 10 lijas. Ciego



REFERENCIA	GRANO	OFERTA
IMP3108	50	3,18 €
IMP3109	80	
IMP3110	120	
IMP3111	180	

115 x 280 mm.

Lote 10 lijas.
8 agujeros.



REFERENCIA	GRANO	OFERTA
IMP3100	50	3,71 €
IMP3101	80	
IMP3102	120	3,18 €
IMP3103	180	

115 x 280 mm.

Lote 10 lijas.
14 agujeros.



REFERENCIA	GRANO	OFERTA
IMP3104	50	3,71 €
IMP3105	80	
IMP3106	120	3,18 €
IMP3107	180	

93 x 185 mm.

Lote 6 lijas.
8 agujeros.



REFERENCIA	GRANO	OFERTA
IMP3112	40	3,82 €
IMP3113	60	
IMP3114	80	
IMP3115	120	

93 x 185 mm.

Lote 6 lijas.
8 agujeros.



REFERENCIA	GRANO	OFERTA
IMP3116	50	3,82 €
IMP3117	80	
IMP3118	120	
IMP3119	180	

93 x 230 mm.

Lote 10 lijas. Ciego



REFERENCIA	GRANO	OFERTA
IMP3132	50	2,65 €
IMP3133	80	
IMP3134	120	
IMP3135	180	

93 x 230 mm.

Lote 10 lijas.
8 agujeros.



REFERENCIA	GRANO	OFERTA
IMP3124	50	2,65 €
IMP3125	80	
IMP3126	120	
IMP3127	180	

RETRÁCTIL

MSE-CRD93X230AS

Lote 10 lijas. 8 agujeros.
Granos surtidos. 93 x 230 mm.

1,59€





BLISTERS

93x93 mm.
6 unidades.



REF.	GRANO	OFERTA
IMP3140	50	2,19 €
IMP3141	80	1,96 €
IMP3142	120	1,91 €
IMP3143	180	1,96 €



RETRÁCTIL

93x93 mm.
6 unidades.



REFERENCIA	GRANO	OFERTA
MSEDELTA93GR60	60	1,48 €
MSEDELTA93GR80	80	
MSEDELTA93GR120	120	
MSEDELTA93GR180	180	



105 x 175 mm.
5 unidades.



REF.	GRANO	OFERTA
IMP3170	50	2,83 €
IMP3171	80	2,92 €
IMP3172	120	
IMP3173	180	



95x135 mm.
5 unidades.



REFERENCIA	GRANO	OFERTA
MSE95x135GR60	60	1,48 €
MSE95x135GR80	80	
MSE95x135GR120	120	
MSE95x135GR180	180	



100 x 150 mm.
6 unidades.



REF.	GRANO	OFERTA
IMP3148	50	4,57 €
IMP3149	80	4,24 €
IMP3150	120	4,03 €
IMP3151	180	



102x152 mm.
5 unidades.



REFERENCIA	GRANO	OFERTA
MSE102GR60	60	1,48 €
MSE102GR80	80	
MSE102GR120	120	
MSE102GR180	180	



72

DISCO OXY 180 mm.

6 unidades. Pulido de calidad. Para madera, pintura, cuero, resinas.



REFERENCIA	GRANO	OFERTA
OXYDF18040	40	4,51 €
OXYDF18080	80	4,40 €
OXYDF180120	120	4,24 €
OXYDF180180	180	4,51 €
OXYDF180ASS	VARIOS	



DISCO MALLA 150 mm.

5 unidades.



REFERENCIA	GRANO	OFERTA
MSE-150RTVB60	60	7,05 €
MSE-150RTVB80	80	
MSE-150RTVB120	120	
MSE-150RTVB180	180	



DISCO OXY 225 mm.

6 unidades. Pulido de calidad. Para madera, pintura, cuero, resinas.



REFERENCIA	GRANO	OFERTA
OXYDF22540	40	4,51 €
OXYDF22560	60	4,51 €
OXYDF22580	80	4,40 €
OXYDF225100	100	4,40 €
OXYDF225120	120	4,24 €
OXYDF225150	150	4,24 €
OXYDF225180	180	4,24 €
OXYDF225220	220	4,24 €
OXYDF225240	240	4,24 €



DISCO MALLA 225 mm.

5 unidades.





REFERENCIA	GRANO	OFERTA
MSE-225RTVB60	60	7,37 €
MSE-225RTVB80	80	
MSE-225RTVB120	120	
MSE-225RTVB180	180	







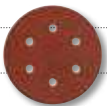

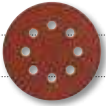

BLISTERS

Discos ø 115 mm. Ciego (6 unid.) - VELCRO		OFERTA
IMP3152	Grano 50.	 2,33 €
IMP3153	Grano 80.	
IMP3154	Grano 120.	
Discos ø 125 mm. 8 agujeros (10 unid.) - VELCRO		OFERTA
IMP3155	Grano 50.	 2,49 €
IMP3156	Grano 80.	
IMP3157	Grano 120.	
IMP3158	Grano 180.	
Discos ø 127 mm. 1 agujero (10 unid.)		OFERTA
IMP3163	Grano 50.	 2,23 €
IMP3164	Grano 80.	
IMP3165	Grano 120.	
Discos ø 150 mm. 6 agujeros (6 unid.) - VELCRO		OFERTA
IMP3166	Grano 50.	 3,07 €
IMP3167	Grano 80.	
IMP3168	Grano 120.	

RETRÁCTIL

Discos ø 115 mm. 8 agujeros (6 unid.) - VELCRO		OFERTA	
MSEDF11540	Grano 40.	 2,12 €	
MSEDF11560	Grano 60.		
MSEDF11580	Grano 80.		
MSEDF115120	Grano 120.		
MSEDF115180	Grano 180.	 2,12 €	
Discos ø 125 mm. 8 agujeros (6 unid.) - VELCRO			OFERTA
MSEDF12540	Grano 40.		
MSEDF12560	Grano 60.		
MSEDF12580	Grano 80.		
MSEDF125120	Grano 120.		
MSEDF125180	Grano 180.	 2,12 €	
Discos ø 150 mm. 8 agujeros (6 unid.) - VELCRO			OFERTA
MSEDF15040	Grano 40.		
MSEDF15060	Grano 60.		
MSEDF15080	Grano 80.		
MSEDF150120	Grano 120.		
MSEDF150180	Grano 180.		
Discos ø 150 mm. Ciego (6 unid.) - VELCRO		OFERTA	
MSEDNF15060	Grano 60.	 2,92 €	
MSEDNF15080	Grano 80.		
MSEDNF150120	Grano 120.		
MSEDNF150180	Grano 180.		

RETRÁCTIL

ARTÍCULO	RETRÁCTIL	OFERTA
LOTE 3 Bandas 75x457 mm		
MSE75X457	Disponibles en grano 40 - 60 - 80 - 120	 2,65 €
LOTE 3 Bandas 75x533 mm		
MSE75X533	Disponibles en grano 40 - 60 - 80 - 120	 2,65 €
LOTE 3 Bandas 100x610 mm		
MSE100X610	Disponibles en grano 40 - 60 - 80 - 100 - 120	 3,92 €

ARTÍCULO	RETRÁCTIL	OFERTA
LOTE 3 Bandas 100x690 mm		
MSE100X690	Disponibles en grano 40 - 60 - 80 - 100 - 180	 3,71 €
LOTE 3 Bandas 100x914 mm		
MSE100X914	Disponibles en grano 60 - 80 - 120 - 180	 9,01 €



BLISTER

ARTÍCULO	GRANO	BLISTER	OFERTA
LOTE 3 Bandas 65x410 mm			
IMP3194	GR40		3,18 €
IMP3195	GR60		
IMP3196	GR80		
IMP3197	GR120		
IMP3198	GR180		
LOTE 3 Bandas 60x400 mm			
IMP3189	GR40		3,18 €
IMP3190	GR60		
IMP3191	GR80		
IMP3192	GR120		
IMP3193	GR180		
LOTE 3 Bandas 75x457 mm			
IMP3199	GR40		3,63 €
IMP3200	GR60		
IMP3201	GR80		
IMP3202	GR120		
IMP3203	GR180		
LOTE 3 Bandas 75x480 mm			
IMP3204	GR40		3,79 €
IMP3205	GR60		
IMP3206	GR80		
IMP3207	GR120		
IMP3208	GR180		
LOTE 3 Bandas 75x510 mm			
IMP3209	GR40		3,82 €
IMP3210	GR60		
IMP3211	GR80		
IMP3212	GR120		
IMP3213	GR180		

ARTÍCULO	GRANO	BLISTER	OFERTA
LOTE 3 Bandas 75x533 mm			
IMP3214	GR40		4,10 €
IMP3215	GR60		
IMP3216	GR80		
IMP3217	GR120		
IMP3218	GR180		
LOTE 3 Bandas 105x620 mm			
IMP3219	GR40		4,24 €
IMP3220	GR60		
IMP3221	GR80		
IMP3222	GR120		
IMP3223	GR180		
LOTE 3 Bandas 100x560 mm			
IMP3174	GR40		5,47 €
IMP3175	GR60		
IMP3176	GR80		
IMP3177	GR120		
IMP3178	GR180		
LOTE 3 Bandas 100x610 mm			
IMP3179	GR40		5,19 €
IMP3180	GR60		
IMP3181	GR80		
IMP3182	GR120		
IMP3183	GR180		
LOTE 3 Bandas 100x690 mm			
IMP3184	GR40		5,41 €
IMP3185	GR60		
IMP3186	GR80		
IMP3187	GR120		
IMP3188	GR180		





ROLLOS LIJA PARED (115 mm.) CRD

Soporte **papel**, adhesivo cola, abrasivo óxido de aluminio.

Madera dura y metal

REFERENCIA	GRANO	OFERTA
MSE-CRD115x560	60	2,65 €
MSE-CRD115x580	80	
MSE-CRD115x5120	120	
MSE-CRD115x5180	180	

5 mt.



REFERENCIA	GRANO	OFERTA
MSE-CRD115x2560	60	12,72 €
MSE-CRD115x2580	80	
MSE-CRD115x2512	120	
MSE-CRD115x2518	180	

25 mt.



ROLLOS LIJA MULTIPRODUCTO (120 mm.) IMJ

Soporte de **tela** abrasiva, extra flexible al corindón, adhesivo doble resina, abrasivo corindón, óxido de aluminio.

Madera dura y metal

REFERENCIA	GRANO	OFERTA
MSE-IMJ115x560	60	9,54 €
MSE-IMJ115x580	80	
MSE-IMJ115x5120	120	
MSE-IMJ115x5180	180	

5 mt.



REFERENCIA	GRANO	OFERTA
IM-213040	40	55,12 €
IM-213060	60	49,82 €
IM-213080	80	
IM-2130100	100	
IM-2130120	120	44,52 €
IM-2130150	150	
IM-2130180	180	49,82 €
IM-2130240	240	

25 mt.



ROLLO LIJA BARNIZ (100 mm.) CCB

Soporte **papel**. Óptimo para la lijadura y acabado en seco de barnices de poliéster y transparentes.

3 mt.



REFERENCIA	GRANO	OFERTA
IM-12449661	180	2,39 €
IM-12449675	240	
IM-12449696	280	
IM-12449724	320	

ROLLO LIJA FLEXIBLE MADERA (100 mm.) PTK

Soporte "J Flex". Tela. Elaboraciones manuales de estampados metálicos y acabados calidad standard.

3 mt.



REFERENCIA	GRANO	OFERTA
IM-12449605	180	4,47 €
IM-12449626	240	
IM-12449633	280	5,57 €
IM-12449654	320	

ROLLO LIJA VELCRO (100 mm.) E28V

Soporte **papel**. Ideal para elaboraciones manuales sobre madera, materias plásticas y láminas metálicas, barnices sobre madera y metal.

3 mt.



REFERENCIA	GRANO	OFERTA
IM-12449864	40	6,89 €
IM-12449885	80	
IM-12449906	100	5,30 €
IM-12449913	150	

ROLLO LIJA MADERA (100 mm.) JFN

Soporte **papel**. Óptimo para la lijadura y acabado en seco de madera, barnices y masillas.

3 mt.



REFERENCIA	GRANO	OFERTA
IM-12449542	40	3,18 €
IM-12449563	60	2,65 €
IM-12449584	80	
IM-12449591	150	

ROLLO LIJA UNIVERSAL (115 mm.) KPF

Soporte **papel** al látex. Flexible como tela, se emplea en seco y húmedo. Ideal para alisar las superficies perfiladas bastas o tratadas. Barnices, madera y materias plásticas.

5 mt.



REFERENCIA	GRANO	OFERTA
IM-217060	60	3,82 €
IM-217100	100	2,39 €
IM-217150	150	
IM-217240	240	

Hojas bimetálicas al cobalto M42 para elevadas prestaciones de corte de metales. Ideales para corte en seco. Gran resistencia y productividad, tanto en materiales macizos, como en perfilados. Todas disponibles en varios dentados:

- **Mayor número de dientes:** válidas para tubo grueso o materiales muy duros.
- **Dentado intermedio:** universales.
- **Dentado mínimo:** Para tubo fino o materiales blandos.
- **(*) Máximo dentado:** Fabricación especial.



	REFERENCIA	DESCRIPCIÓN	VÁLIDAS PARA MOD. CON NG SYSTEM	OFERTA BLISTER 2 UDS.
1440	FMCINT6NG120	1440x13x0.65 Z/1" 6	NG 120 / ABS NG120	45,58 €
	FMCINT812NG120	1440x13x0.65 Z/1" 8/12	NG 120 / ABS NG120	
	FMCINT14NG120	1440x13x0.65 Z/1" 14	NG 120 / ABS NG120	
	FMCINT18NG120	1440x13x0.65 Z/1" 18 (*)	NG 120 / ABS NG120	
1750	FMCINT6NG160	1735x13x0.9 Z/1" 6	NG-160 / ABS NG160	51,94 €
	FMCINT610NG160	1735x13x0.9 Z/1" 6/10	NG-160 / ABS NG160	
	FMCINT14NG160	1735x13x0.9 Z/1" 14	NG-160 / ABS NG160	

	REFERENCIA	DESCRIPCIÓN	VÁLIDAS PARA	OFERTA
1330	FMCINT6780	1335x13x0.65 Z/1" 6	782 / 783 / 780 P / mod. XL y ABS 105	44,52 €
	FMCINT812780	1335x13x0.65 Z/1" 8/12	782 / 783 / 780 P / mod. XL y ABS 105	
	FMCINT14780	1335x13x0.65 Z/1" 14	782 / 783 / 780 P / mod. XL y ABS 105	
	FMCINT18780	1335x13x0.65 Z/1" 18 (*)	782 / 783 / 780 P / mod. XL y ABS 105	
1440	FMCINT812784	1440x13x0.65 Z/1" 8/12	784 XL	44,52 €
	FMCINT14784	1440x13x0.65 Z/1" 8/14	784 XL	
1750	FMCINT461750	1735x20x0.9 Z4/6	1750 XL - 1750 XLABS	53,00 €
	FMCINT8121750	1735x20x0.9 Z8/12	1750 XL - 1750 XLABS	
	FMCINT6101750	1735x20x0.9 Z6/10	1750 XL - 1750 XLABS	
	FMCINT141750	1735x20x0.9 Z14	1750 XL - 1750 XLABS	
1750	FMCINT6785	1735x13x0.9 Z/1" 6	785 P / 785XL	50,88 €
	FMCINT610785	1735x13x0.9 Z/1" 6/10	785 P / 785XL	
	FMCINT14785	1735x13x0.9 Z/1" 14	785 P / 785XL	
2200	FMCINT46792	2140x19x0.9 Z/1" 4/6	2200XL / 2200DAXL	63,60 €
	FMCINT610792	2140x19x0.9 Z/1" 6/10	2200XL / 2200DAXL	
	FMCINT14792	2140x19x0.9 Z/1" 14	2200XL / 2200DAXL	
2500	FMCINT610251	2480x27x0.9 6/10	N250DAXL Y N251DAXL	74,20 €
	FMCINT46251	2480x27x0.9 4/6	N250DAXL Y N251DAXL	
	FMCINT812251	2480x27x0.9 8/12	N250DAXL Y N251DAXL	
	FMCINT14251	2480x27x0.9 10/14	N250DAXL Y N251DAXL	
2750	FMCINT610310	2750x27x0.9 6/10	N310DA/DG	79,50 €
	FMCINT10/14310	2750x27x0.9 10/14	N310DA/DG	

PARA MÁQUINAS ESTÁTICAS



CÓDIGO	∅ D=mm.	Grueso B=mm.	Eje D=mm.	Z	OFERTA
DM25430Z42	254	3,2	30	42	25,00 €
DM25430Z60	254	3,2	30	60	27,00 €
DM25030Z42	250	3,2	30	42	25,00 €
DM30030Z48	300	3,2	30	48	29,00 €
DM30530Z48	305	3,2	30	48	56,18 €
DM30530Z72	305	3,2	30	72	41,34 €
DM30530Z96	305	3,2	30	96	47,70 €
DM35030Z54	350	3,5	30	54	55,00 €
DM35030Z84	350	3,5	30	84	59,00 €

PARA MÁQUINAS PORTÁTILES



CÓDIGO	∅ D=mm.	Grueso B=mm.	Eje D=mm.	Z	CON ANILLO DE REDUCCIÓN	OFERTA
SC-3901802704	160	2,4	30	24		15,00 €
SC-3901802705	160	2,2	30	48		18,00 €
DM19030Z30PRT	190	2,8	30	30	30/20, 30/16	16,00 €
DM19030Z52PRT	190	2,8	30	52	30/20, 30/16	20,00 €
DM20030Z30PRT	200	2,8	30	30	30/25, 30/20, 30/18	20,00 €
DM21030Z24	210	2,8	30	24	-	20,00 €
SC-7901800601	210	2,8	30	30	-	18,00 €
SC-7901800602	210	2,8	30	72	-	28,00 €
SC-7901200705	216	2,8	30	48	-	29,00 €

ESPECIAL MADERA MADERA PLASTIFICADA

Discos silenciosos



CÓDIGO	∅ D=mm.	Grueso B=mm.	Eje D=mm.	Z	OFERTA
DM25030Z60	250	3,2	30	60	51,00 €
DM25030Z80	250	3,2	30	80	69,00 €
DM25030Z72	300	3,2	30	72	59,00 €
DM30030Z96	300	3,2	30	96	98,08 €

ESPECIAL ALUMINIO

Discos silenciosos



CÓDIGO	∅ D=mm.	Grueso B=mm.	Eje D=mm.	Z	OFERTA
DB25020Z96	300	3,2	30	96	108,34 €

77

PARA ALUMINIO

CÓDIGO	∅ D=mm.	Grueso B=mm.	Eje D=mm.	Z	OFERTA
DA21030Z48	210	3,0	30	48	19,00 €
DA25030Z80	250	3,2	32	80 (*)	35,00 €
DA35030Z108	350	3,0	30	108	89,00 €
DA40030Z96	400	3.6/3.0	30	96	104,94 €
DA42030Z120	420	3.8/3.2	30	120	149,00 €
DA50030Z120	500	4.0/3.4	30	120	199,00 €
DA53030Z120	530	4.0/3.4	30	120	219,00 €



PARA DESBROZADORAS

CÓDIGO	∅ D=mm.	Grueso B=mm.	Eje D=mm.	Z	OFERTA
DB25020Z20	250	2,8	20	20	20,14 €

MADERA CON CLAVOS.

CÓDIGO	∅ D=mm.	Grueso B=mm.	Eje D=mm.	Z	OFERTA
DC31530Z20	315	3,2	30	20	21,20 €

ANILLOS DE REDUCCIÓN

Juego de tres uds.

REFERENCIA	REDUCCIÓN	OFERTA
SUCA151825	30/16 • 30/20 • 30/22	7,50 €
SUCA162022	30/15 • 30/18 • 30/25	7,50 €



DISCOS DE LÁMINAS PARA HIERRO

REFERENCIA	GRANO	OFERTA
DL11540H	40	1,59 €
DL11560H	60	1,59 €
DL11580H	80	1,59 €
DL115100H	100	1,59 €
DL115120H	120	1,59 €
DL12540H	40	1,91 €
DL12560H	60	1,91 €
DL12580H	80	1,91 €
DL125100H	100	1,91 €
DL125120H	120	1,91 €
DL18040H	40	5,30 €
DL18060H	60	5,30 €
DL18080H	80	5,30 €
DL180100H	100	5,30 €
DL180120H	120	5,30 €



Embalaje de 20 unidades. (ø 115 - 125) 10 unidades. (ø 180)

DISCOS DE LÁMINAS PARA INOXIDABLE

REFERENCIA	GRANO	OFERTA
DL11540INOX	40	1,70 €
DL11560INOX	60	1,70 €
DL11580INOX	80	1,70 €
DL115100INOX	100	1,70 €
DL115120INOX	120	1,70 €
DL12540INOX	40	2,01 €
DL12560INOX	60	2,01 €
DL12580INOX	80	2,01 €
DL125100INOX	100	2,01 €
DL125120INOX	120	2,01 €
DL18040INOX	40	5,30 €
DL18060INOX	60	5,30 €
DL18080INOX	80	5,30 €
DL180100INOX	100	5,30 €
DL180120INOX	120	5,30 €



Embalaje de 20 unidades. (ø 115 - 125) 10 unidades. (ø 180)

FRESAS METAL DURO PARA MADERA

78

FRKIT6 (MANGO 8)

Composición:

- Fresa cóncava R 6.35 mm.
- Fresa recta 6 mm.
- Fresa moldura R 6.3 mm.
- Fresa enrasadora 12.7 mm.
- Fresa recta 12 mm.
- Fresa cola milano 12.7 mm.

Caja 6 unidades

19,08 €

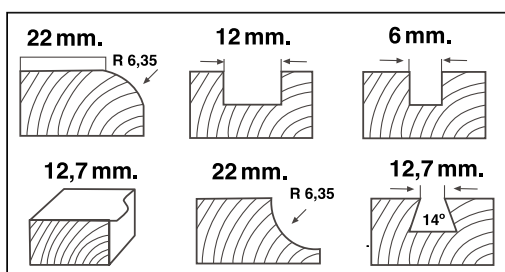

FRESAS PARA PERNIOS

REFERENCIA	MEDIDAS		OFERTA
	Ø	MANGO	
FRH 12	12	6	24,42 €
FRH 13	13	6	24,42 €
FRH 14	14	6	24,42 €
FRH 15	15	6	24,42 €



FRESAS DE DISCO

REFERENCIA	MEDIDAS		OFERTA
	A	B	
FR 65	40	1,5	11,68 €
FR 66	40	2,0	11,63 €
FR 67	40	2,5	11,63 €
FR 68	40	3,0	11,63 €
FR 69	40	4,0	11,63 €
FR 70	40	5,0	11,63 €
FR 71	40	6,0	13,89 €

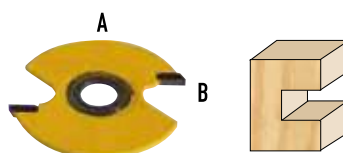

MANGO PARA FRESAS DE DISCO

REFERENCIA	EJE	OFERTA
MANGO 6		
FR 72	8	9,32 €
FR72/6	6	8,79 €
MANGO 8		
FR 73	8	9,38 €
FR73/6	6	8,85 €



FRESAS INDIVIDUALES

REFERENCIA		MEDIDAS				OFERTA
MANGO 6	MANGO 8	A	B	D+B	R	
FR 40-6	FR 40-8	22,2	12,7	49	4,8	23,27 €
FR 41-6	FR 41-8	25,4	12,7	49	6,3	15,36 €
FR 42-6	FR 42-8	28,6	12,7	49	7,9	17,15 €
FR 43-6	FR 43-8	31,8	15,9	52	9,5	18,54 €
FR 44-6	FR 44-8	38,1	19,1	55	12,7	20,83 €



REFERENCIA		MEDIDAS				OFERTA
MANGO 6	MANGO 8	A	B	D+B	R	
FR 1-6	FR 1-8	3	11	51		4,64 €
FR 2-6	FR 2-8	4	11	51		5,11 €
FR 3-6	FR 3-8	5	11	51		5,11 €
FR 4-6	FR 4-8	6	19	57		6,46 €
FR 5-6	FR 5-8	6	25	61		6,46 €
FR 7-6	FR 7-8	8	19	57		6,46 €
FR 8-6	FR 8-8	8	25	63		6,46 €
FR 9-6	FR 9-8	10	19	51		6,99 €
FR 10-6	FR 10-8	10	32	63		6,46 €
FR 11-6	FR 11-8	12	19	54		6,99 €
FR 12-6	FR 12-8	12	32	63		6,99 €
FR 13-6	FR 13-8	14	19	52		9,65 €
FR 14-6	FR 14-8	16	25	57		6,99 €
FR 15-6	FR 15-8	18	19	52		9,22 €
FR 16-6	FR 16-8	20	19	52		9,22 €
FR 22-6	FR 22-8	22	19	52		9,22 €
FR 25-6	FR 25-8	25	19	52		11,37 €
FR 76-6	FR 76-8	15	19	52		6,99 €

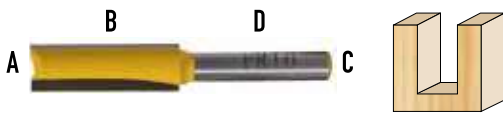

REFERENCIA		MEDIDAS				OFERTA
MANGO 6	MANGO 8	A	B	D+B	E	
FR 51-6	FR 51-8	31,8	12,7	50	45°	29,72 €

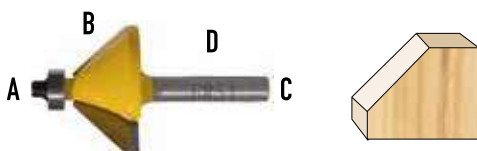

REFERENCIA		MEDIDAS				OFERTA
MANGO 6	MANGO 8	A	B	D+B	E	
FR 34-6	FR 34-8	12,7	12,7	44	14°	14,88 €



REFERENCIA		MEDIDAS				OFERTA
MANGO 6	MANGO 8	A	B	D+B	R	
FR 47-6	FR 47-8	22,2	14,3	52	6,3	26,44 €
FR 48-6	FR 48-8	25,4	14,3	52	7,9	20,32 €
FR 49-6	FR 49-8	28,6	14,3	52	9,5	22,55 €
FR 50-6	FR 50-8	34,9	19,1	57	12,7	25,34 €

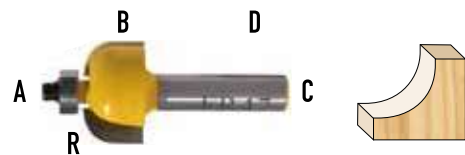

REFERENCIA		MEDIDAS			OFERTA
MANGO 6	MANGO 8	A	B	D+B	
FR 31-6	FR 31-8	12,7	12,7	44(60°)	17,99 €
FR 32-6	FR 32-8	12,7	12,7	44(90°)	12,94 €
FR 33-6	FR 33-8	19,1	15,9	44(90°)	11,47 €



REFERENCIA		MEDIDAS				OFERTA
MANGO 6	MANGO 8	A	B	D+B	R	
FR 35-6	FR 35-8	22,2	12,7	49	4,8	6,05 €
FR 36-6	FR 36-8	25,4	12,7	49	6,3	15,36 €
FR 37-6	FR 37-8	28,6	12,7	49	7,9	17,15 €
FR 38-6	FR 38-8	31,8	15,9	52	9,5	17,99 €
FR 39-6	FR 39-8	38,1	19,1	55	12,7	19,75 €

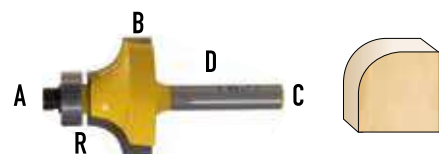

REFERENCIA		MEDIDAS				OFERTA
MANGO 6	MANGO 8	A	B	D+B	R	
FR 26-6	FR 26-8	6,3	4,8	44	3,2	12,77 €
FR 27-6	FR 27-8	9,5	6,3	38	4,8	8,61 €
FR 28-6	FR 28-8	12,7	7,9	38	6,3	10,36 €
FR 29-6	FR 29-8	15,9	9,5	38	7,9	11,99 €
FR 30-6	FR 30-8	19,1	12,7	38	9,5	16,20 €

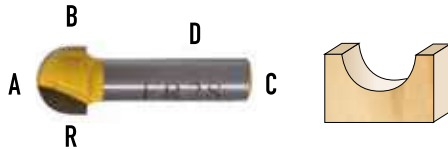

REFERENCIA		MEDIDAS				OFERTA
MANGO 6	MANGO 8	A	B	D+B	R	
FR 45-6	FR 45-8	25,4	15,9	52	4,0	23,27 €
FR 46-6	FR 46-8	34,9	22,2	57	6,3	24,40 €

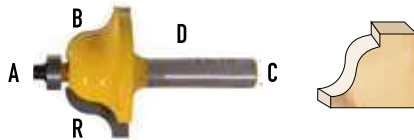

REFERENCIA		MEDIDAS					OFERTA
MANGO 6	MANGO 8	A	B	D+B	R1	R2	
FR 53-6	FR 53-8	25,4	15,9	52	4,0	4,0	23,69 €
FR 54-6	FR 54-8	34,9	22,2	57	6,3	6,3	34,40 €
FR 88-6	FR 88-8	37,1	12,7	52	4,7	1,6	34,40 €
FR 89-6	FR 89-8	38,1	15,9	53	6,0	3,6	35,09 €

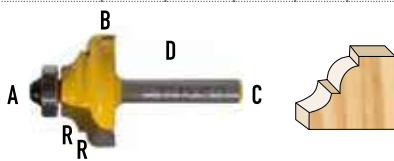

REFERENCIA		MEDIDAS				OFERTA
MANGO 6	MANGO 8	A	B	D+B	R	
FR 83-6	-	22,2	13,5	54	3,2	11,25 €
FR 84-6	FR 84-8	28,2	16,0	57	4,8	15,04 €
FR 85-6	FR 85-8	31,8	19,0	60	7,0	29,72 €

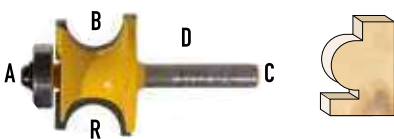

REFERENCIA		MEDIDAS				OFERTA
MANGO 8	A	B	D+B	R	R	
FR 62-8	19	12	54	45°	6,3	57,66 €



REFERENCIA		MEDIDAS				OFERTA
MANGO 8	A	B	D+B	R	R	
FR 63-6	FR 63-8	24	12	55	25°	78,67 €



REFERENCIA		MEDIDAS				OFERTA
MANGO 6	MANGO 8	A	B	D+B	R	
FR 57-6	FR 57-8	9,5	7,9	50	3,2	35,09 €

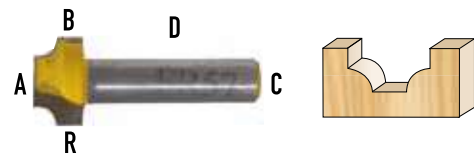

REFERENCIA		MEDIDAS				OFERTA
MANGO 6	MANGO 8	A	B	D+B		
FR 58-6	FR 58-8	12,7	25,4	63		9,95 €
FR 59-6	FR 59-8	16,0	15,9	50		8,27 €



REFERENCIA		MEDIDAS			OFERTA
MANGO 6	MANGO 8	A	B	D+B	
FR 64-6	FR 64-8	6,3	19,1	63	9,22 €



REFERENCIA		MEDIDAS					OFERTA
MANGO 6	MANGO 8	A	B	D+B	R1	R2	
FR 55-6	FR 55-8	34,9	13,5	52	4,8	3,6	34,40 €

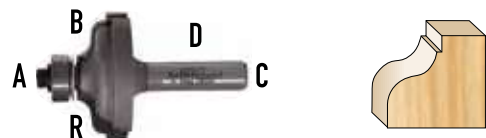

REFERENCIA		MEDIDAS					OFERTA
MANGO 6	MANGO 8	A	B	D+B	R1	R2	
FR 93-6	FR 93-8	19,1	12,7	54	3,7	4,0	21,20 €

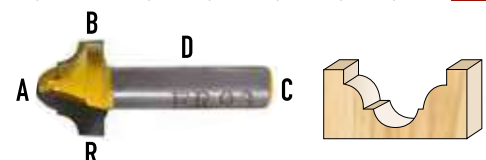

CORONA XWY-02K006

Ø 60-67-75-83-95 mm.

Alta potencia de corte. Hojas de acero al tungsteno. Con broca de centrado de 10 mm. Vástago hexagonal y cuerpo metálico. Profundidad de corte 33 mm.

Usos:

- Madera.
- Yeso encartonado.
- Planchas de construcción.
- Metales no féreos.



6,89€

CORONA XWY-02K005

Ø 26-35-38-45-50-56-63 mm.

Alta potencia de corte. Hojas de acero al tungsteno. Con broca de centrado de 8 mm. Vástago hexagonal y cuerpo metálico. Profundidad de corte 18 mm.

Usos:

- Madera.
- Yeso encartonado.
- Planchas de construcción.
- Metales no féreos.



3,18€

CUCHILLAS REVERSIBLES PARA CEPILLOS ELÉCTRICOS PORTÁTILES

Válidas para mod.: RYOBI, AEG, BLACK & DECKER, BOSCH, DEWALT, HITACHI, MAKITA, METABO, SKILL, VIRUTEX.

REFERENCIA	MEDIDAS	OFERTA
CU-REBLI82	Bliester 2 uds. 82 mm.	4,24 €
CU-RECAJA10/78B	Caja 10 uds. 78 mm.	18,02 €
CU-RECAJA10/82B	Caja 10 uds. 82x55x1,1 mm.	18,02 €



CORTACÍRCULOS XWY-06K003

Corte de 30 a 250 mm.

Con cuchillas ajustables, para cortes en techos, paredes y suelos

Usos:

- Madera laminada.
- Madera contrachapada.
- Yeso laminado.
- Planchas acrílicas.



9,54€

CORTACÍRCULOS XWY-06K010

- Con cuchillas ajustables.
- Contra-chapado, plástico, pladur, escayola, yeso...
- Con pantalla protectora.



Especial para techos

Corte regulable de 40 a 250 mm.

Cuchilla corta

Ref. XWY-06K010-1
P.V.P.: 3,00 €

Cuchilla Widia

Ref. XWY-06K010-2
P.V.P.: 3,00 €

Cuchilla larga

Ref. XWY-06K010/1
P.V.P.: 3,50 €

79,50€

CEPILLOS CIRCULARES DE TELA DE ALGODÓN

Para pulir el metal usando taladros y esmeriladoras.

REF.	Ø	VÁSTAGO	EJE	OFERTA
ITBSP80	80	6 X 27	/	6,59 €
ITBSP150	150	/	16 - 20	10,14 €
ITSP200	200	/	20	17,30 €



CEPILLOS DE TAZA DE ACERO LATONADO

Eje M-14

Para cepillado de grandes superficies en astilleros, calderería, construcción, etc. con amoladoras angulares.

REF.	Ø	Ø HILO	OFERTA
ITT80	75	0,30	7,57 €
ITT100	100	0,30	10,04 €
ITT120	120	0,30	13,85 €
ITT80 Inox	75	0,30	14,83 €
ITT100 Inox	100	0,30	24,46 €



CEPILLOS DE TAZA TRENZADOS DE ACERO

Eje M-14

Para rebabas, satinado y pulido de grandes superficies con amoladoras angulares.

REF.	Ø	TRENZA	OFERTA
ITTU71	70	18	14,57 €
ITTU85	85	22	25,95 €
ITTU111	105	26	32,07 €
ITTU131	120	32	39,64 €



CEPILLOS CÓNICOS DE ACERO

Eje M-14

Para limpiezas de soldaduras y superficies irregulares en taladros y amoladoras angulares.

REFERENCIA	Ø	Ø HILO	TRENZA	OFERTA
ITC090BOX (*)	95	0,30	18	7,16 €
ITC0120BOX	120	0,30	22	16,11 €
ITCZ95BOX	95	0,30	26	12,77 €
ITCZ120BOX	120	0,30	32	15,00 €
ITC090INOX	95	0,30	32	14,00 €



(*) Acero latonado.

CEPILLOS CIRCULARES DE ACERO LATONADO

Ø Hilo 0,30

Para eliminación de óxidos, rebabas, pinturas, limpieza de piezas de fundición, cardado de pieles y cuero. Para usar con esmeriladoras.

REF.	Ø	EJE	ESPESOR	OFERTA
IT3102	100	16	15	15,39 €
IT3122	125	16	17	15,55 €
IT4152	150	16	20	16,27 €
IT4203	200	20	29	26,62 €
IT6253	250	35	30	51,95 €



CEPILLOS

Limpieza de todo tipo de adherencias, pinturas y óxidos.

REF.	CALIDAD	Ø HILO	OFERTA
CE-SPIDBOX	Acero latonado	0.30	1,93 €
CE-SPIDBOXINOX	Acero Inox.	0.15	2,42 €
ITSPIDPVC	PVC	0.30	4,55 €



CEPILLOS DE ACERO PARA TALADROS

Eliminación de óxidos, pinturas y adherencias. Preparación de superficies para la pintura. Pulido de piezas metálicas.

REF.	Ø	EJE	Ø HILO	ESPESOR	OFERTA
ITBG50	50	6 X 25	0,30	9	2,42 €
ITBG75	75	6 X 25	0,30	9	3,76 €
ITBG100	100	6 X 25	0,30	9	4,52 €
ITBTE50	50	6 X 30	0,30	/	3,20 €
ITBTE75	75	6 X 30	0,30	/	4,08 €
ITBGG73	70	6 X 25	0,30	12	12,24 €
ITBGG103	100	6 X 25	0,30	16	16,14 €
ITBP25	25	6 X 21	0,30	25	4,77 €
ITP20INOX15	22	6 X 21	0,15	22	10,23 €
ITP20INOX	22	6 X 21	0,30	22	8,41 €
ITBGZ71	70	6 X 25	0,50	15	16,14 €



CEPILLO PARA DESBROZADORA

Para desbrozadoras de más de 1,5 HP. Medida: 200x25,4x38 mm./z 36. 10.000 r.p.m. max. Acero 0,50 mm.

REFERENCIA	OFERTA
ITCZ200	52,55 €



MIRA EL VIDEO



W125

Depósito: 600 ml.
Tamaño de trabajo:
5m²/10 min
WG-2409303



CLICK & PAINT



62€

W150

Depósito: 600 ml.
Tamaño de trabajo:
5m²/10 min
WG-2359328



CLICK & PAINT



77€

W575 FLEXIO

Depósito: 1300 ml. +800 ml.
Tamaño de trabajo:
15m²/6 min
630 W.
WG-2397237



CLICK & PAINT

Depósito
adicional
WG-2361730



149€

W450PLUS

Depósito: 1300 ml.
Consumo 110 W.
460 W.
Tamaño de trabajo:
15m²/10 min
WG-2373631



CLICK & PAINT

Extensión
adicional
WG-2361756



134€

W990 FLEXIO

Depósito 600 ml.
Tamaño de trabajo:
15m²/5 min
WG-2361559



CLICK & PAINT

Depósito
adicional
WG-2361730



199€

W950 FLEXIO

Depósito: 800 ml.
Tamaño de trabajo: 15m²/6 min
630 W.
WG-2361555



CLICK & PAINT

Depósito
adicional
WG-2361730



238€

W490

Depósito: 1300 ml
(pintura plástica)
800 ml (esmaltes)
350 W.
WG-2401082

CLICK & PAINT



59€

W690 FLEXIO

Depósito: 1800 ml (pintura para pared)
800 ml (lacas y barnices)
630 W. Para trabajos grandes: 15m²/6 min
Manguera 3,5 mt.
WG-2370368

CLICK & PAINT

Regulación de
caudal de aire
variable
Extensión
adicional
WG-2361756



157€

CP150M

Manguera: 7,5 mt.
Boquillas incluidas 311 - 517
300 W.
WG-2394312

HEA HIGH EFFICIENCY AIRLESS



**Lijadora adicional
WG-2370395**

CLICK & PAINT



338€

CP250M PACK

Caudal: 1,25 lt/min.
Manguera: 9 mt.
Boquillas máx. 517
550 W.
WG-2371053
No recomendada
para productos
con base disolvente.

HEA HIGH EFFICIENCY AIRLESS



**Extensión adicional
WG-517700
(30 cm.)**



474€

CP350R PACK

Caudal: 1,50 lt/min.
Manguera: 15 mt.
Boquillas incluidas
311 - 517
600 W.
WG-2371073

HEA HIGH EFFICIENCY AIRLESS



**Extensión adicional
WG-517700
(30 cm.)**



590€

CP350M

Caudal: 1,50 lt/min.
Manguera: 15 mt.
Boquillas incluidas
311 - 517
600 W.
WG-2371057

HEA HIGH EFFICIENCY AIRLESS



641€

FURNO 100

320 W. Flujo de aire 100/150 lt/min.
WG-2398546



33€

FURNO 300

1.600 W. 400°C - 575°C
2 niveles de temperatura
WG-2359348



26€

FURNO 500

2.000 W. 60°C
600°C
2 boquillas
WG-2359352

Sistema de auto-enfriamiento



48€

FURNO 750

2.000 W. 50°C
650°C
4 boquillas
Maletín
WG-2359358

**Sistema de auto-enfriamiento
Display digital**



77€

LIJADORA STUDIO

TIPO MOUSE

130 W.
Longitud del cable 2 mts.
Dimensiones: 21x13x14 cm.
WG-2370395

Incluye 3 lijas



31€

Tipo de pintura: Pinturas plásticas Esmaltes, lacas y barnices

TURBINA SIN CABLE

Incluye dos depósitos (pintura plástica y esmaltes).
Batería 18 V.
(Compatible con baterías BOSCH).
2.5 AH.



Proximamente
Diciembre
2021

**CONSULTAR
PRECIO**

FRONTAL STANDARD

CLICK & PAINT

Depósito: 800 ml.
Para trabajos pequeños y medianos.
WG-2361730



21 €

PROLONGADOR HVLP

CLICK & PAINT

Extensión Universal Extra.
Ergonómico, para trabajar cómodamente en paredes y techos.
WG-2361756



28 €

FRONTAL GRAVEDAD

CLICK & PAINT

Depósito: 150 y 600 ml.
Para trabajos pequeños y medianos.
WG-2412884



33 €

WG-517101

Pistola Airless Control
Pro metal.
WG-517101



182 €

WG-517

Boquilla HEA Control Pro



49 €

EXTENSIÓN CONTROL PRO



REFERENCIA	LARGO (CM)	OFERTA
WG-517700	30	79,00 €
WG-517701	60	89,00 €

SET DE DOS FILTROS



REFERENCIA	COLOR	OFERTA
WG-418711	ROJO	19,00 €
WG-418712	AMARILLO	19,00 €
WG-418713	BLANCO	19,00 €

DISCO SPEED SHIELD

Disco recortador con soporte de boquilla rosca G.
WG-538905



135 €

QUITAPAPELES STEAMFORCE

2.000 W. Depósito: 4 l.
Tiempo vaporizado máx.: 80 min
WG-2410385



57 €

RODILLO DIY AUTOALIMENTADO

Depósito: 550 ml.
Rendimiento: 5 m2
Longitud: 1,25 m.
WG-2419944

RODILLOS	ANCHO x LARGO mm.	OFERTA
WG-0998230	230x12	6,00 €
WG-0245717	230x 20	6,00 €

34 €



GAMA INDUSTRIA

BT36TR

Bomba de trasvase. Ref.: BT-213601

36 l/min

CAUDAL	36 l/min
RELACIÓN	1:1
PRESIÓN	1:8 BAR
PESO	4 KG
CONEXIÓN	3/8"
MEDIDAS ENTRE TORNILLOS	15x10,5 cm

* Disponible BT-213601 Atex

362€



BT48TR

Bomba de trasvase. Ref.: BT-214801

48 l/min

CAUDAL	48 l/min
RELACIÓN	1:1
PRESIÓN	1:8 BAR
PESO	4 KG
CONEXIÓN	1/2"
MEDIDAS ENTRE TORNILLOS	16x12 cm

* Disponibles:
BT-214801 Acero Atex
BT-214805 Nylon Atex
BT-214804 Inox Atex

525€



BT-36

Bomba neumática doble membrana con carro.

Ref.: BT-213602

36 l/min

CAUDAL	36 l/min
RELACIÓN	1:1
PRESIÓN	1:8 BAR
PESO	13 KG
CONEXIÓN	1/2"
MEDIDAS ENTRE TORNILLOS	16x12 cm

86

Disponible mod. BT-48
(48 l/min.) Ref.: BT-214802
P.V.P.: 849 €

649€

Accesorios opcionales:

- BT-MU00933: Regulador 0-6 Bar P.V.P.: 135€
- BT-S71PRONA: Pistola baja presión
1/3" BT-S71PRONA1.3 P.V.P.: 99€
1/5" BT-S71PRONA1.5 P.V.P.: 99€
1/8" BT-S71PRONA1.8 P.V.P.: 99€
- BT-886875: Manguera 7.5 mt
(1/4" - Rosca F) P.V.P.: 37€
- BT-60012: Sistema de aspiración P.V.P.: 42€



BT-KITESMALTES

Conjunto bomba especial para esmaltes.

DEPÓSITO	2 lt.
MANGUERA	3.5 mt
PISTOLA BAJA PRESIÓN	6,8 Bar max.
PRESIÓN MÁX.	3,5 Bar
CONEXIÓN	1/4"

Accesorios opcionales:

- BT-S71PRONA: Pistola baja presión
1/3" BT-S71PRONA1.3 P.V.P.: 99€
1/5" BT-S71PRONA1.5 P.V.P.: 99€
1/8" BT-S71PRONA1.8 P.V.P.: 99€
- BT-886875: Manguera 3.5 mt
(1/4" - Rosca F) P.V.P.: 27€
- BT-33200: Depósito 2 lt. P.V.P.: 140€



269€

SC-SG1000

Generador 230 V. - 650/700 W.
1,6 HP. Sistema de regulador de voltaje. (AVR) Motor gasolina. 4 lt. Motor 2 tiempos. 17,5 Kg.

1x230 V.

149€



SC-SG3200

Generador 230 V. - 2.500/2.800 W.
6,5 HP. Sistema de regulador de voltaje. (AVR) Protector sobrecargas, voltímetro y advertencia nivel de aceite. Motor gasolina. 15 lt. Motor 4 tiempos. 47 Kg.

2x230 V.

379€



SC-SG7100

Generador 400/230 V. - 5.000/5.500 W.
15 HP. Sistema de regulador de voltaje. (AVR) Protector sobrecargas, voltímetro y advertencia nivel de aceite. Motor gasolina. 25 lt. Motor 4 tiempos. 89 Kg.

1x230 V.
2x400 V.

899€



SC-SG2000

Generador 230 V. 1600/2.000 W.
2.86 HP. Inverter 71Db
Construcción compacta y ligera para un fácil transporte. Motor gasolina 3.2 Lt. Motor 4 tiempos. 21 Kg.

2x230 V.

599€



87

SC-FS3600

Cortadora de cerámica
900 W. - 230 V.
Alto corte 90°. 36 mm.
Alto corte 45°. 29 mm.
Largo de corte: 920 mm.
Mesa: 1290x400 mm.
59 Kg.

Láser
Ø Disco
200 mm.

499€



SC-FS4700

Cortadora de cerámica
1.200 W. - 230 V.
Alto corte 90°. 40 mm.
Alto corte 45°. 34 mm.
Largo de corte: 1.200 mm.
Mesa: 1377x400 mm.
66 Kg.

Láser
Ø Disco
230 mm.

660€



SC-DH1300PLUS

Martillo 1.250 W.
5 Julios - 0-850 r.p.m.
4.500 golpes/min.
Max. diam broca SDS PLUS 30 mm.
4 funciones. Incluye brocas,
punta, cincel y maleta.
6 kg.

Rotativo
Picador



115 €

SC-DH12000MAX

Martillo 1.050 W.
9 Julios - 0-480 r.p.m.
3.780 golpes/min.
Max. diam broca SDS MAX 38 mm.
Incluye punta y cincel.
En caja de transporte
6 kg.

Rotativo
Picador



179 €

SC-AB1600

Martillo 1.600 W. 50 Julios.
Anti-vibración. Incluye
2 cinceles. 16 kg.

Demoledor
Hexagonal
30 mm.
Maleta



209 €

SC-AB1900

Martillo 1.900 W. 60 Julios.
Anti-vibración.
Incluye ruedas, cincel y punta.
16,5 Kg.

Demoledor
Hexagonal
30 mm.
Maleta



233 €

SC-VS1000

Pisón. 6,5 HP - Gasolina.
10.000 N. Ancho
compactación: 345x285.
Vibración 450. 650 vpm.
78 kg. Ruedas de
transporte.

Profundidad de
compactación
40-60 mm.



1.175 €

SC-EB1700

Ahoyadora. 1,77 HP - 2 fuerzas - Gasolina.
9.600 r.p.m.
Brocas de 100 - 150 - 200 mm.
Incluye 3 brocas.
2 velocidades.
51,7 c.c.
22,5 Kg.

Máxima
perforación
800 mm.



289 €

Brocas:

SC-7904702701 - 100 mm. P.V.P.: 25 €

SC-7904702702 - 150 mm. P.V.P.: 28 €

SC-7904702703 - 200 mm. P.V.P.: 50 €

SC-HP1200S

Compactadora
6,5 HP. - Gasolina 15.000 N
Velocidad 25 m/min
Velocidad de trabajo: 600m²/h
Placa 450x350 mm.
196 c.c.
Ruedas de transporte
60 Kg.

Profundidad de compactación: 25 cm.



499€

SC-HP1800S

Compactadora
6,5 HP. Gasolina. 23.000 N.
Velocidad 25 m/min
Velocidad de trabajo: 650 m²/h
Placa 550x440 mm. 196 c.c.
Ruedas de transporte
88 Kg.

Profundidad de compactación: 30 cm.



575€

SC-HP2200S

Compactadora
6,5 HP. - Gasolina 25.000 N
Velocidad 25 m/min
Velocidad de trabajo: 650 m²/h
Placa 550x440 mm. 196 c.c.
Ruedas de transporte
102 Kg.

Profundidad de compactación: 35 cm.



659€

SC-HP2500S

Compactadora
6,5 HP. - Gasolina. 30.000 N
Velocidad 25 m/min
Velocidad de trabajo: 750 m²/h
Placa: 630x400 mm.
196 c.c.
Ruedas de transporte
125 Kg.

Profundidad de compactación: 40 cm.
Reversible



1.250€

SC-HP3000S

Compactadora
9 HP. - Gasolina. 30.500 N
Velocidad 25 m/min
Placa: 730x450 mm. 270 c.c.
Ruedas de transporte
161 Kg.

Profundidad de compactación: 50 cm.
Reversible



1.650€

SC-CB01

Polipasto cadena
Capacidad de carga: 1000 Kg.
Elevación: 3.000 mm.
Cadena de rueda
libre para controlar
la mano.



1.000 Kg

65€

SC-CB02

Polipasto cadena
Capacidad de carga: 2.000 Kg.
Elevación: 3.000 mm.
Cadena de rueda
libre para controlar
la mano.



2.000 Kg

99€

SC-HRS250

Polipasto eléctrico
Motor: 230 V.
Potencia: 530 W.
Carga sin rodillo: 125 Kg.
Carga con rodillo: 250 Kg.
Altura de elevación
sin rodillo: 12 m.
Altura de elevación
con rodillo: 6 m.



125/250

109€

SC-120o

Sierra de mesa
Motor: 230 V.
Potencia: 2.200 W. Disco 315 m.
Mesa 800x550 mm.
Capacidad de corte 83 mm.
Capacidad de corte 45° 49 mm.



299€

SC-DTB20-20PROS

Atornillador - percutor

ESFUERZO DE TORSIÓN	45 Nm
PAR DE AJUSTE	18 + 3
PORTABROCAS	2 - 13 mm.
VELOCIDAD	0 - 450/0 - 1600 min 2 x 20 V.
BATERÍA	DC/2 Ah Lithium 220 - 240 V.
CARGADOR	50 - 60 Hz.

159€



206 pzas.

Cargador rápido

SC-PL55

Sierra circular
 Motor: 230 V.- 240 V.
 Potencia: 370 W.
 Ø Disco: 160 mm. Ø Eje: 20 mm.
 Velocidad del disco: 5.500 r.p.m.
 Corte máx. 90°: 55 mm.
 Corte máx. 45°: 41 mm.
 Capacidad de oscilación: 0-45°



199€

SC-PL75

Sierra circular
 Motor: 230 V.- 240 V.
 Potencia: 1.600 W.
 Ø Disco: 210 mm.
 Ø Eje: 20 mm.
 Velocidad del disco: 4.500 r.p.m.
 Corte máx. 90°: 75 mm.
 Corte máx. 45°: 55 mm.
 Capacidad de oscilación: 0-45°



209€

SC-PLM1800

Cepilladora.
 Motor: 230 V.- 240 V.
 Potencia: 1.500 W.
 Anchura 330 mm. regrueso
 Regrueso 152 mm.
 Profundidad de pasada 2.8 mm.

Caja de transporte



459€

2 Cuchillas: SC-7902200607 P.V.P.: 38,50 €

SC-OSM600

Lijadora de banda y eje oscilante
 Motor: 230 V.- 240 V. Oscilación 16 mm.
 Husillo 13 /19/26/38/51 mm. Tabla 410x425 mm.
 Mesa ajustable 45°. Rodillos desde 13-19-26-38-51 y 76 mm.

Maleta

Juego de 6 rodillos:
 C-7903400701 GR80
 P.V.P.: 60 €
 SC-7903400702 GR120
 P.V.P.: 60 €
 SC-7903400703 GR180
 P.V.P.: 60 €
 SC-7903400704 GR240
 P.V.P.: 60 €
 Juego de 3 Bandas
 GR100. SC-7903400705
 (80/100/120 mm.)
 P.V.P.: 35 €



279,95€

SC-PM1800D

Mezclador doble varilla
 Motor: 230 V.- 240 V.
 Potencia: 1.800 W.
 2 velocidades 0.450/0.790 r.p.m.
 Volumen máx. 140 Lt.



149,95€

2 varillas: SC-5907802701 P.V.P.: 35 €

SC-AEROSPADE

Multifunción 5 en 1
 Consumo máximo 280 l/min
 Presión máxima 6.3 Bar
 Trabajos de excavación:
 Menores: 2.5 Hp.
 Medios - Techos: 3 Hp.
 Pesados, roturas: 4 Hp.



199€

BIENVENIDO A LA CASA CONECTADA

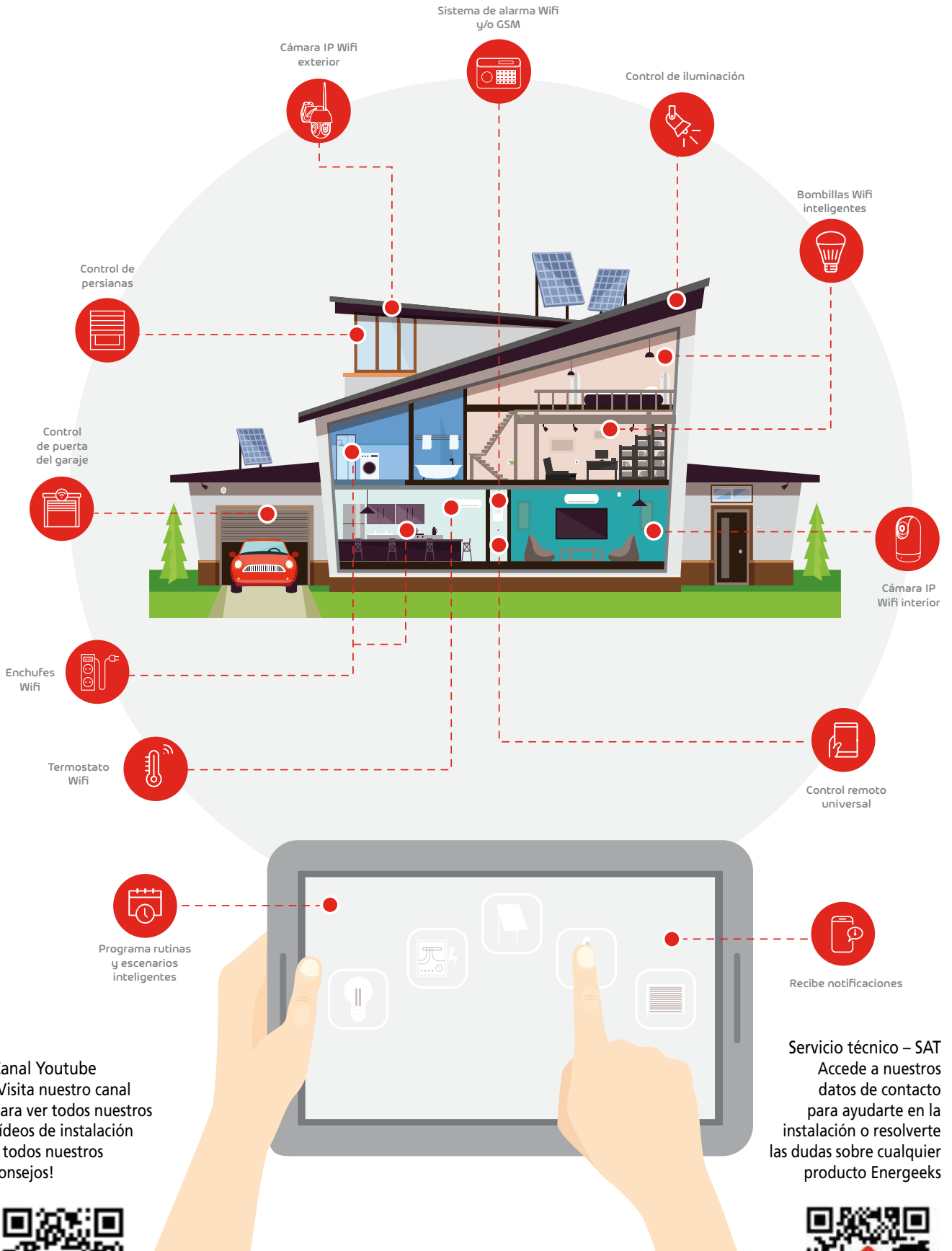

Canal Youtube
¡Visita nuestro canal para ver todos nuestros videos de instalación y todos nuestros consejos!

Servicio técnico – SAT
Accede a nuestros datos de contacto para ayudarte en la instalación o resolverte las dudas sobre cualquier producto Energeeks





EG-EW003MC
Enchufe Wifi inteligente con medidor de consumo.



14€ Pack 3 uds.: EG-EW004MC
OFERTA: 39 €

EG-EW006MC
Enchufe Wifi doble inteligente



20,50€

Enchufe doble

EG-EW005MC
Enchufe Wifi inteligente con 2 Usb.



16€

2 Usb

EG-EW001MC
Enchufe Wifi inteligente con luz multicolor.

Luz multicolor



16€

EG-BW001MC
Base múltiple inteligente 4T+4x USB



36€

4 Usb

EG-IR001
Control remoto universal Wifi.



18€

Control A/A a distancia

EG-A60BOMBW001
Bombilla Wifi inteligente A60. Casquillo E27. 806 Lm. 9 W. Bluetooth RGB+CCT

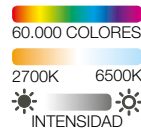

8,97€



EG-GU10BOMBW001
Bombilla Wifi inteligente GU10. 345 Lm. 5 W. Bluetooth RGB+CCT

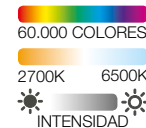

8,97€



LEYENDA ICONOS



SEGURIDAD

EG-AW002 PLUS

Sistema de alarma Wifi 3.0
 Conexión wifi.
 Avisos de intrusiones y control desde un smartphone.
 Ampliable con hasta 60 sensores y/o accesorios y compatible con cualquiera de nuestras cámaras.

Conectable a la nube



119€

* Tarjeta micro SD no incluida.

ACCESORIOS ADICIONALES Y CÁMARAS COMPATIBLES PARA EG-AW002 PLUS Y EG-AWG002

Accesorios

Mando a distancia
 Ref. EG-MD002



7,99€

Sensor de apertura
 Ref. EG-SA002



9,99€

Sensor de movimiento
 Ref. EG-SM002



14,99€

Sirena exterior
 Ref. EG-S002



39,99€

Cámaras

EG-CIP001



EG-CIP002



EG-CIPEXT001



CIPBAT001



CIPFOCO001



CIPFOCO002



EG-AWG002

Sistema de alarma Wifi.
 Dotada de tarjeta SIM con conectividad GSM (no datos) y/o una conexión Wifi, para recibir avisos y controlar el sistema desde un telefono móvil.
 Dispone de una batería de emergencia y automáticamente, pasa a modo GSM.
 Ampliable con hasta 60 sensores y/o accesorios y compatible con cualquiera de nuestras cámaras.

WIFI+GSM



129€

* Tarjeta micro SD no incluida.



VIDEOVIGILANCIA

EG-CIP001
Cámara IP WIFI
motorizada.

**Visualiza en
directo desde
tu móvil**

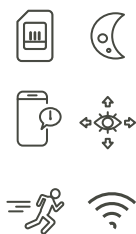

29,99€

EG-CIP002
Cámara IP WIFI
motorizada SENTINEL
1080 p. RJ45

**Función
autotracking**



39,99€

EG-CIPEXT001
Cámara IP WIFI
motorizada exterior
DEFENDER
Rotativa 360°
1080p. RJ45

**IP65
Wifi
Para exterior
Función
autotracking**



69,99€

EG-CIPBAT001
Cámara IP Wifi con batería
recargable RANGER

**IP65
Interior / Exterior
Batería
Soporte imantado**



84,95€

EG-CIPFOC001
Cámara IP Wifi con foco
OBSERVER

IP65

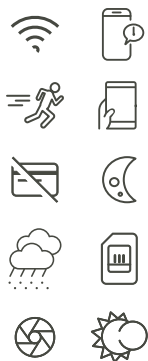

69,99€

EG-CIPFOC002
Cámara IP Wifi con doble foco
OBSERVER II

IP65

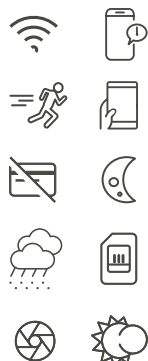

119,99€

VIDEOVIGILANCIA

EG-CCTV001PLUS

Sistema de vigilancia.
CCTV FULL HD
(4 cámaras + DVR 4 canales)

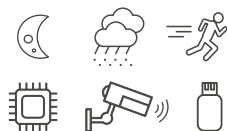

275€

EG-CCTV001

Sistema de vigilancia. CCTV FULL HD
(2 cámaras + DVR 4 canales)



235€

MINI ALARMAS

ALARMA TIMBRE SIN HILOS
con detector de movimiento
Ref. EG-ALT001



16€

ALARMA DE APERTURA
para puertas y ventanas
Ref. EG-AL001



9€

ALARMA DE APERTURA
para puertas y ventanas
con mando a distancia
Ref. EG-AL002



18€

PACK DE 4 ALARMAS
de apertura para puertas
y ventanas
Ref. EG-AL006



4,50€

ALARMA PERSONAL
Ref. EG-ALV001



3,50€

ALARMA TIMBRE
con detector de movimiento
Ref. EG-ALT002



7€

ALARMA DE APERTURA
para puertas y ventanas
con teclado
Ref. EG-AL003



20€

ALARMA DE VIBRACIÓN
ANTI-INTRUSIÓN
Ref. EG-AL004



11€

ALARMA ANTI-INTRUSIÓN
para puertas y ventanas
de cristal
Ref. EG-AL005



6€

ALARMA ANTI-INTRUSIÓN
para pomo/manilla puertas
Ref. EG-ALV002



3,70€

ALARMA ANTI-INTRUSIÓN
tope de puertas
Ref. EG-ALV003



2,99€



CONTROL DE TEMPERATURA

EG-VALVKIT001

Pack inicial válvula termostática. Control de radiador individual. Programación, escenarios. Control a distancia. **IMPORTANTE:** Se necesita tener previamente una llave termostática instalada en el radiador.



105€

EG-VALV001

Válvula termostática adicional. Control de radiador individual. Programación, escenarios. Control a distancia. **IMPORTANTE:** Se necesita tener previamente una llave termostática instalada en el radiador.



37€



EG-TERM001

Termostato WIFI. Control de calderas individuales. Control a distancia. Se puede instalar en la pared, sustituyendo al actual, o de sobremesa.



95€



INSTALACIÓN SOBREMESA: CENTRAL WIFI A LA CALDERA

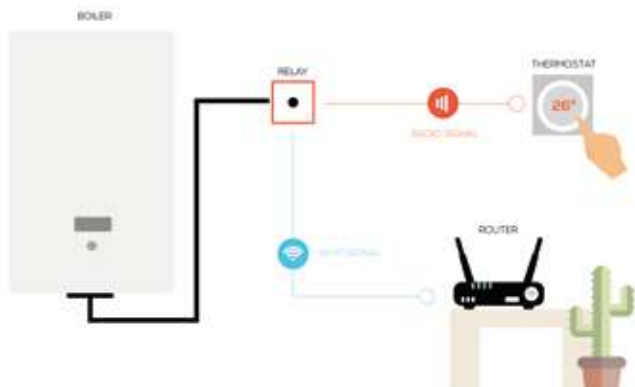

INSTALACIÓN PARED: TERMOSTATO A LA CALDERA

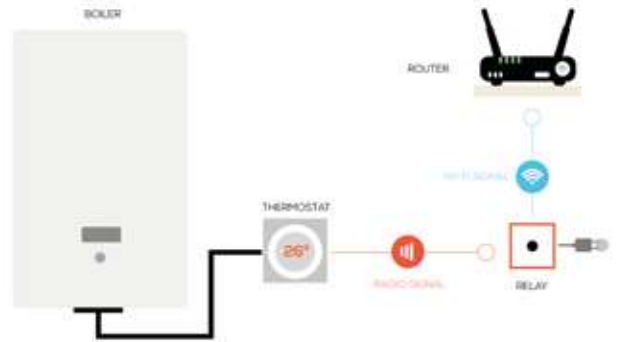

DECORATIVA EXTERIOR

SE406AM

Bombilla antimosquitos.
LED 6,8 W. 680 lúmenes



3,50€

EG-GRL5230VB

Guirnalda exterior 5 mt.
10 casquillos



E27



22€

EG-GRL5230VW

Guirnalda exterior 5 mt.
10 casquillos



E27



25€

EG-PACK5EEGRLPRVBJR

Pack 5 bombillas para
guirnalda.
4000 K.
1.2 W.



E27



RGB LED

6,99€

EG-PACK5EEGRLP

Pack 5 bombillas
para guirnalda.
2700 K.
1,2 W.



E27



Luz cálida

6,99€

98

EG-GRL5PRVBT

Guirnalda exterior 5m/5
bombillas
1.2 W.



RGB LED



16€

EG-GRL5PCWT

Guirnalda exterior 5m/5
bombillas led
7000 K. - 1.2 W.

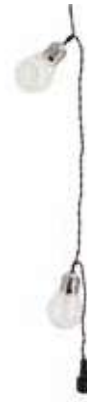

Luz fría



16€

EG-LP545

Luz led con velcro y pilas. 5
LED. Autónoma.
2700 K
1.2 W.



3AAA



5,50€

PV-BL5475

Pack 3 luces
LED adhesivas.

Para uso interior



5,99€

PV-BL6885

Pack 6 luces LED adhesivas.

Para uso interior



9,99€

DECORATIVA EXTERIOR

EG-PR10WR

Proyector recargable.
700 lúmenes.

35€



PR20WR

Proyector recargable.
1400 lúmenes.

52€



EG-PR20WT

Proyector
trípode LED.
1600 lúmenes.
20 W.

35€

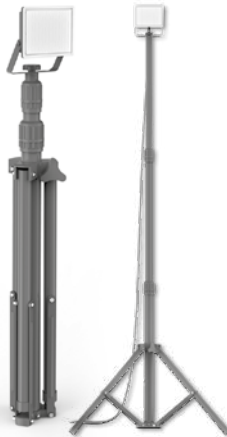

EG-PR20W2T

2 proyectores
trípode LED.
1600 lúmenes.
20 W.

43€



EG-PR10WF

Proyector LED
10W.
800 lúmenes.

Hasta 30 mt.

18€



EG-PR30WF

Proyector LED 30W.
2400 lúmenes.

Hasta 50 mt.

25€



EG-PR50WF

Proyector LED 50W.
4000 lúmenes.

Hasta 70 mt.

32€



EG-PR10WM

Proyector de pared LED
exterior 10W.
800 lúmenes.

Hasta 30 mt.



10€



EG-PR30WM

Proyector exterior
LED 30W.
2400 lúmenes.

Hasta 50 mt.



15€



EG-PR50WM

Proyector exterior
LED 50W.
4000 lúmenes.

Hasta 70 mt.



18€



EG-PR20WMD

Proyector de pared
LED exterior. 50
W. 1600 lúmenes.
Con sensor de
movimiento.

Hasta 40 mt.



18€



EG-PR50WMD

Proyector de pared
LED exterior. 50
W. 4000 lúmenes.
Con sensor de
movimiento.

Hasta 40 mt.



24€



EG-PR20WMRVB

Proyector de
pared LED
exterior. 15W.
1300 lúmenes.

Hasta 50 mt.



34€



LINTERNAS

EG-FR100

Linterna frontal
LED 100 lúmenes.
Pilas incluidas.

Hasta 15 mt.



2 MODOS
50% | 100%



5€

EG-LP1072

Linterna portátil
con cargador.
200 lúmenes.
Pilas incluidas.

Hasta 10 mt.



COLGADOR

2 MODOS
50% | 100%



5€



ORIENTABLE
360°



MAGNÉTICO



EG-BL222

Linterna LED
con colgador.
200 lúmenes.
Pilas incluidas.



MAGNÉTICO



COLGADOR

2 MODOS
50% | 100%



9€



RESISTENTE

Hasta 8 mt.



EG-LT250M

Linterna LED retráctil.
250 lúmenes.
Pilas incluidas.

Hasta 20 mt.



3AAA



COMPACTA

8€



EG-T0100XS

Linterna LED metálica.
100 lúmenes.
Pilas incluidas.

Hasta 70 mt.



6€



IP63

WATER
RESIST



1AA

EG-T0600M

Linterna LED metálica.
600 lúmenes. Pilas
incluidas. Pilas incluidas.

Hasta 200 mt.

3 MODOS
50% | 100% | FLASH



10€



IP65

WATER
RESIST



4AAA

100

EXTERIOR SOLAR

EG-LSBK3SOLARRVB

Tira LED
3 mt.

RGB LED



24,95€

EG-LSAK3SOLAR

Tira LED
3 mt.

Luz fría



24,95€

EG-S01017

Pack 8 balizas
blanco/RGB.

Hasta 8 h.



24,95€

EG-PACK2PS0350

Pack 2 focos
LED.

Hasta 8 h.

34€



EG-PRS700D

Foco solar con sensor de
movimiento. Detección
a 5 m. 700 lúmenes

Luz fría



29,95€

EG-APS300

Foco-aplique
solar con sensor de
movimiento. Detección a 7 m.
300 lúmenes.

Luz fría



21€

EG-SORETRO3

Bombilla
decorativa solar

Hasta 8 h.



7€

NOVEDADES

EG-SDVEL

Lámpara pendel latón
Casquillo E27



9,95€

EG-SDV03EB

Lámpara pendel aluminio
Casquillo E27



9,95€

EG-SDVEG

Lámpara pendel dorada
Casquillo E27



9,95€

EG-RFDHE150BCAN

Bombilla deco rejilla oval negra
Casquillo E27



16,50€

EG-RFDHE150ECAN

Bombilla deco rejilla esfera negra
Casquillo E27



16,50€

EG-RFDHE150CCAN

Bombilla deco rejilla cilíndrica negra
Casquillo E27



16,50€

EG-RFDHE150BCAB

Bombilla deco rejilla oval blanca
Casquillo E27



16,50€

EG-RFDHE150ECAB

Bombilla deco rejilla esfera blanca
Casquillo E27



16,50€

EG-RFDHE150CCAB

Bombilla deco rejilla cilíndrica blanca
Casquillo E27



16,50€

EG-RFDE280B125S

Bombilla LED deco espiral
Casquillo E27
1800K
300 lúmenes
4W (equivale
28W)



11,99€

EG-RFDE300BLG

Bombilla LED deco vintage verde
Casquillo E27
2200K
340 lúmenes
8W
(equivale
28W)



15,99€

EG-RFDE806GBOCW

Bombilla LED deco opalina
Casquillo E27
4000K
806 lúmenes
8W (equivale 60W)



19,99€

VINOLO ADHESIVO PARA SUELO		OFERTA 5 uds.
F-30006MAK	1000X100 mm A/N	6,29 €
F-30007MAK	1000X100 mm R/B	
F-30008MAK	1000X100 mm A/N	
F-30012	Ø 30 mm Amarillo	

Antideslizantes



Ref.: F-30006MAK



Ref.: F-30007MAK



Ref.: F-30008MAK



Ref.: F-30012

CINTA ADHESIVA			OFERTA
F-112	Base polipropileno N/A 0,5x66 mt	36 uds	3,76 €
F-117	Base polipropileno R/B 0,5x66 mt	36 uds	3,76 €
F-136	Base caucho B/R 0,5x33 mt	24 uds	7,56 €
F-137	Base caucho N/A 0,5x33 mt	24 uds	7,56 €



*Impresión 1 cara en rojo o negro.

SEÑALIZACIÓN COMBINADA		
F-614	Adhesivo "Lavado de manos"30x40cm.	10 uds
F-617	Adhesivo "Aforo máximo"40x30cm.	10 uds
F-618	Adhesivo "Aforo limitado"40x30cm.	10 uds
F-621	Adhesivo "Normas de seguridad"30x40cm.	10 uds

UNIDAD **2,73€**

Estas señales se pueden fabricar en PE, adhesivo o aluminio



F-618



F-617



F-614



F-621

SHOPGEL HIDROALCOHÓLICO

Gel/Jabón líquido neutro a base de alcoholes para la higienización de las manos. Válido para uso en áreas de manipulación de alimentos. No necesita aclarado. Transparente y sin perfume. Contiene glicerina.

Limpiador
Higienizante
Protector



Ref.: F-143/500ML

0,5L

UNIDAD
3,14 €

Pedido mínimo 25 uds.



Ref.: F-143/1LT

1L

UNIDAD
4,19 €

Pedido mínimo 12 uds.



Ref.: F-143/5LT

5L

UNIDAD
16,80 €

Pedido mínimo 4 uds.

F-143P305

Alcohol isopropílico se puede usar como limpiador, desengrasante o disolvente para eliminar todo tipo de suciedad, rayas, huellas dactilares de las superficies, dispositivos electrónicos, teléfonos móviles, dispositivos ópticos... etc. Se evapora rápidamente sin dejar residuos. Pedido mínimo 12 uds.

400 mL

UNIDAD
6,04 €



Transparente
Sin perfume
Pureza del 90 %

CE-E010SST

Generador de ozono O₃. Temporizador con 16 programas. Programación diaria o semanal. Acero.

Cobertura máx. desinfección: 200m² en 1h. Suministro inmediato desde que se enciende el interruptor

PRODUCCIÓN DE OZONO (gr)	10
VENTILADOR (m ₃ /h)	115
VOLTAJE (V)	220-240
FRECUENCIA (Hz)	50/60
POTENCIA (W)	85
LpA SONORO 3 mt. (dB(A))	52
LONGITUD DEL CABLE (m)	3.0

EUO₃TA.org
European Ozone Trade Association



586,95 €

CE-E010WTH

Generador de ozono O₃. Temporizador con 16 programas. Programación diaria o semanal. Inoxidable.

Cobertura máx. desinfección: 200m² en 1h. Suministro inmediato desde que se enciende el interruptor

PRODUCCIÓN DE OZONO (gr)	10
VENTILADOR (m ₃ /h)	115
VOLTAJE (V)	220-240
FRECUENCIA (Hz)	50/60
POTENCIA (W)	85
LpA SONORO 3 mt. (dB(A))	52
LONGITUD DEL CABLE (m)	3.0

EUO₃TA.org
European Ozone Trade Association



651 €

G140-61N

Nobuk.
Tallas 36 a 47

S3 SRC

Metal FREE



59€



G138107C

Serraje.
Tallas 36 a 47

S1P SRC



26,50€



G138106C

Serraje.
Tallas 36 a 47

S1P SRC



26€



G140-60N

Nobuk.
Tallas 36 a 47

S3 SRC

Metal FREE



59€



GYSHU1500C

Tejido Mesh.
Tallas 37 a 47

SRA S1P HRO

Metal FREE



55€



GYSHU1504N

Tejido Mesh.
Tallas 36 a 47

S1P SRA

Metal FREE



59€



GYSHU1502N

Tejido Mesh.
Tallas 36 a 47

S1P SRA

Metal FREE



59€



GYSHU1503N

Tejido Mesh.
Tallas 36 a 47

S1P SRA

Metal FREE



59€



GYSHU1506N

Tejido Mesh.
Tallas 36 a 47

S1P SRA

Metal FREE



59€



G138840C

Serraje.
Tallas 36 a 48

S1P SRC

Metal FREE



39€



G1388601C

Nobuk.
Tallas 35 a 47

S3 SRC

Metal FREE



44€



G1388602C

Nobuk.
Tallas 35 a 47

S3 SRC

Metal FREE



45€



G140-40PC

S3 SRC

Piel flor negra. Puntera de composite y plantilla anti-perforante. Tallas 36 a 42



39€



G140-41PC

S3 SRC

Piel flor negra. Puntera de composite y plantilla anti-perforante. Tallas 36 a 42



38€



ZF140-50VF

S1P SRA

Piel serraje negro. Puntera de composite y plantilla anti-perforante. Tallas 36 a 47



31,45€



ZF138-10F

S1P SRC

Piel serraje gris. Puntera y plantilla acero. Tallas 36 a 47



19,95€



ZF-60055S

S1P SRA

Piel negro, puntera y plantilla acero inox. Tallas 36 a 48



16€



ZF-50066S

S1P SRA

Piel negro, puntera y plantilla acero inox. Tallas 36 a 47



16€



AR-132/RNG

Nylon / PVC

Traje impermeable verde Tallas M-L-XL-XXL.



9,99€

MONO MULTIBOLSILLOS

Tallas S-M-L-XL-XXL.

- F-991210 AZULINA
- F-991211 MARINO
- F-991212 CAQUI



14,95€

F-991121

Chaleco multibolsillos de nylon reforzado.



11,55€

AR-140/161

S5 SRA

Bota de agua verde, con puntera y plantilla acero. Tallas 37 a 47

PVC



16,75€

DUNLOP
PROTECTIVE FOOTWEAR

G0529C

Guantes de hilo continuo elástico gris en nylon con spandex y palma recubierta de espuma de nitrilo negra. Con puntos antideslizantes. Tallas 8-9-10

Nitrilo



2,30 €

G348843C

Guantes nylon elástico verde. Palma recubierta de espuma de latex Tallas 8 y 10

Látex



1,82 €

G34874C

Guantes de nylon elástico gris con palma recubierta de espuma de nitrilo negra. Tallas 8-9-10

Nitrilo



2,10 €

G348841C

Guantes de nylon elástico azul, con palma recubierta de espuma de látex gris. Tallas: 8-9-10

Látex



1,58 €

G34894C

Guantes de hilo continuo elástico negro con palma y dorso recubierto de espuma de nitrilo doble recubrimiento. Palma estriada. Tallas: 8-9-10

Nitrilo



2,99 €

F-121/15

Guantes polietileno desechables de 0,9 grs/m. Pedido mínimo: 10.000 uds. En bolsas individuales de 100 uds.



0,89 €



106

F-057C

Guantes en hilo continuo de nylon, recubierto de nitrilo gris, sin costuras. Óptima sensibilidad. Tallas 8, 9 y 10



0,62 €

F-05270C

Guantes en nylon elástico, con la palma recubierta de poliuretano negro, puños de nylon y látex. Dorso aireado. Tallas 8, 9 y 10



0,62 €

F-0525C

Guantes en nylon elástico, con la palma recubierta de poliuretano blanco, puños en nylon y látex. Dorso aireado. Tallas 8, 9 y 10



0,62 €

F-005BC

Guantes en piel flor de vacuno, blancos con ribete. Discreta sensibilidad. Espesor de la piel: 0,8 - 1 mm. Tallas 8, 9 y 10



1,99 €

AR-1390Y

Guantes en tejido interlock algodón 100%, impregnado de NBR ligero, puño en malla, dorso ventilado. Buena sensibilidad. Talla 10



1,01 €

F-020

Guantes en serraje vacuno, manguito en tela reforzado, dorso algodón 100%. Palma, pulgar e índice reforzados. Espesor de la piel: 1,2-1,3 mm. Óptima sensibilidad. Talla XL



1,67 €

F-039

Guantes 88PBS en piel flor de cerdo gamuza, dorso y manguito en algodón 100%. Espesor piel flor de: 0,8-0,9 mm. Buena sensibilidad. Tallas 8 y 10

Piel Flor



0,74 €

F-992002

Rodilleras de goma espuma negra. Sujeción con banda plástica ajustable.

Básica



8,80 €

F-992008

Rodilleras profesionales con gel de silicona en su interior. Sujeción con banda ancha de velcro.

Confort



16,50 €

F-992016

Rodilleras profesionales. Sujeción con bandas elásticas y cierre velcro.

Flexible



13,20 €

107

AR-235371010000

Mascarilla sin válvula (caja 20 uds.)

FFP1



16 €

AR-2353720100

Mascarilla sin válvula (caja 20 uds.)

FFP2



18 €

AR-2353730400

Mascarilla sin válvula (caja 20 uds.)

FFP3



41 €

AR-2353710300UD

Mascarilla con válvula (caja 12 uds.)

FFP1



13 €

AR-23537203500

Mascarilla con válvula (caja 12 uds.)

FFP2



15 €

AR-125F

Mascarilla con válvula (caja 12 uds.)

Alta Toxicidad FFP3



27 €

AR-2351745100

Mascarilla con 1 filtro de gas A1 745 incluido.



11,03€

AR-2351755801

Mascarilla con 2 filtros de gas A1B1E1K1 incluidos.



24,15€

AR-142/40F

Mascarilla de caucho termoplástico. Con 2 filtros de gas A1 incluidos.



13,64€

AR-142/37F

Mascarilla de caucho termoplástico. Con 2 filtros de gas A2P3 incluidos. Especial fitosanitario.



24,15€

AR-732N

Máscara facial completa de silicona. (No incluye filtros)



66,15€

* Consultar gama y precios de filtros para las diferentes mascarillas.

108

AR-569-I

Gafa en policarbonato incoloro con el frente de una sola pieza y tira frontal de poliamida azul. Patillas extensibles tipo espátula. Protección lateral. Resistente al impacto de pequeños proyectiles.



2,60€

AR-580-I

Gafa monolente incolora en policarbonato. Se pueden sobreponer a las gafas de vista. Ideal para visitantes. Tratamiento anti-vaho y anti-arrañazos.



1,99€

AR-595-I

Gafa en policarbonato incoloro. Frente de una sola pieza y tira de poliamida en forma de arco, color negro. Patillas extensibles tipo espátula.



3,50€

AR-599-G

Gafa de policarbonato panorámica gris.



5,85€

F-142/40

Gafa máscara con montura integral en policarbonato. Lente panorámica anti-vaho y anti-arrañazos. Ventilación directa a través de agujeros.



1,70€

AR-5RG

Casco de protección de polietileno alta densidad con regulador. Incorpora banda anti-sudor. Varios colores.

 AR-5RGL

 AR-5RGAM

 AR-5RGAZ



4,50€

AR-5R

Casco de obra en polietileno ajustable. Varios colores.

 AR-5RBL  AR-5RAM

 AR-5RAZ  AR-5RRO



2,40€

F-C/19

Pantalla protectora de acetato transparente de 30 micras con banda de polietileno regulable.



4,95€

F-142/210

Visera policarbonato transparente con elástico. Eficaz protección contra impactos de alta velocidad (baja y media energía) y salpicaduras.



4,40€

F-142/2100

Visera policarbonato transparente con arnes regulable. Eficaz protección contra impactos de alta velocidad (baja y media energía) y salpicaduras.



7,70€

F-142/110-15

Gorra de protección tipo "beisbol", antigolpes (protege la cabeza). Diseño en tela (100% algodón) con protección interior en ABS acolchado. Orificios de ventilación.



8,50€

109

AR-CHSR

Barboquejo con mentonera. Válido para cascos de protección AR-5RG y AR-5R.



1,60€

F-142/25

Auricular anti-ruido SNR-27 db.(*) Con almohadilla para mayor comodidad y mejor adaptación.



4,75€

F-142/250

Auricular anti-ruido profesional SNR-29db.(*) Diadema resistente. Acolchados en goma y tejido suave. Regulación de altura de las copas.



6,75€

CX-2651010100

Arnés anti-caídas. 10 BASIC
Cinta de 45 mm.
Hebillas de regulación
de piernas

13€



CX-2651010200

Kit Arnés 10 BASIC
+Mosquetones

21€

CX-2651043100

Arnés anti-caídas
ATLAS.
Cintas de poliéster
de 45 mm.
Cinturón y perneras
acolchadas. 3 aros
porta-materiales.
Hebillas de
regulación.

140 Kg.



125€

CX-2651252100

Arnés anti-caídas
MAXIPRO
Punto de anclaje en
dorsal en hebilla "D"
de acero de 8 mm.
Punto de enganche
frontal compuesto
por dos gazas. Banda
dorsal acolchada.



32€

CX-2651025200

Cinturón de sujeción 25-CN
Banda dorsal
acolchada con
hebillas.
Con cuerda
reguladora
y mosquetón.



29€

CX-2651259100

Línea de vida horizontal HORIZONT
Cinta de poliéster naranja de 35 mm.
Longitud 20 m. Elemento de trincaje
tipo carraca con doble bloqueo de
seguridad.



51€

CX-2702111120

Línea de vida vertical SEMI 11
Longitud 20 m.

54€



CX-2702111150

Línea de vida
vertical SEMI 11
Longitud 50 m.

155€

110

CX-2702003200

Absorbedor de energía. 31-A
Longitud 1,6 m. Con dos
mosquetones. Mod.30 y Mod. 31.

36€



CX-2702003800

Absorbedor de energía. 31-A
Longitud 1,6 m. Con dos
mosquetones mod.30

22€

CX-2702101100

Elemento de amarre
U.29/1 SEMI
Cuerda de poliamida
de \varnothing 11 mm. y gaza
a cada extremo.

1,5 mt.

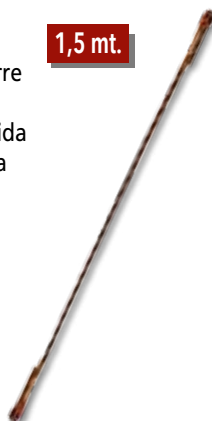

10,50€

CX-2702100601

Absorbedor de energía 35 SEMI
Con banda de absorción y
elemento de amarre en Y de
poliamida de 11 mm.
3 conectores: 1 del mod. 32
y 2 del mod. 31.
Válido para arnés
21CATEX

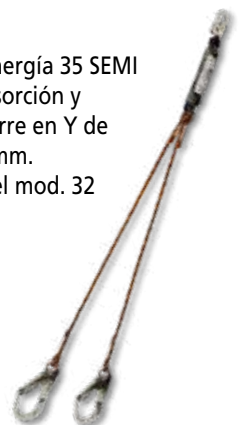

67€

CX-2702005110

Línea de anclaje
flexible. Para uso
vertical. Poliamida
de 3 cabos. 115 gr/m.
Acabados: Lazada
y nudo terminal o
guardacabos en los
extremos \varnothing 14 mm.
Longitud a demanda.



29€

CX-2702003100

Dispositivo anti-caídas deslizante
ADA 14. Con cierre
de seguridad.
Longitud: Con
cuerda de 10 a
100 m, en
tramos de 10 m.



45€

CX-2707001400

Dispositivo anti-caídas ROC
Aluminio anodizado. Para
cuerdas de 10,5 a 12,7 mm.
homologadas.



56€

CX-2703001100

Mosquetón 30
Conector de acero.
Cierre automático
y bloqueo manual.
Ø abertura 16 mm.



3,50€

CX-2703001200

Mosquetón 31
Conector de acero.
Con mecanismo de
cierre y bloqueo
de seguridad
automáticos.
Ø abertura 54 mm.



11€

CX-2703001700

Mosquetón KH-ALU. Aluminio.
Conector en forma de "D".
Bloqueo automático.
Desbloqueo en tres
tiempos. Ø abertura
20 mm.



11€

CX-2705002100

Bloqueador de
cuerda NAHUEL
Aluminio.
Bloqueador de
colocación frontal
para progresión
sobre cuerda fija.
Ø 8 - 13 mm.



32€

CX-2705003200

Dispositivo de descenso.
PCXPLOER
Sistema de seguridad
antipánico y función de
bloqueo gradual.



222,86€

CX-2705001100

Puño de ascenso
derecho SARYU
Aluminio. Ø de
trabajo de 8 a
13 mm.



36€

CX-2706001200

Asiento de suspensión
prolongada
Madera. 67x24 cm.
Acolchamiento en
glúteos. 3 argollas
portamateriales.
Longitud de cinta
regulable.



109€

CX-2706100130

PETATE SPORT
30 lt.



65€

CX-2705004100

PEDAL DE YUMA
Fabricado en cinta.
Regulable.
Con un maillón.

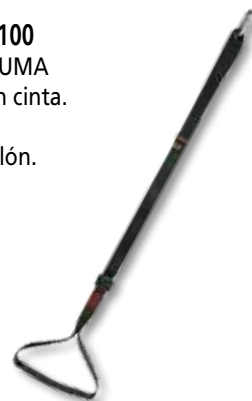

36€

CX-2707002200

Dispositivo anti-caidas retráctil
con 2 conectores. Climax 30.
Carcasa en ABS.
Absorbedor de energía.
Elemento de amarre a partir
de cinta de poliamida de 49 mm.
Longitud 2,5 m.



61,48€

CX-2707003110

10M. Dispositivo anti-caidas retráctil
con conector Climax 30.
Carcasa en ABS.
Absorbedor de energía.
Cable de acero de Ø 4,8 mm. y 10 m.
Conector Climax KH-GIRO
Ø19 mm.



277,26€

PANTALÓN ACOLCHADO

Bicolor
Talla: S a 4XL.
G1362610C gris/naranja
G1362640C naranja/negro

GOODYEAR



19,95 €

CHALECO MULTIBOLSILLOS

Bicolor. Talla: S a 4XL.
Ref.G137905C
gris/naranja
Ref.G1379050C
negro/naranja

GOODYEAR



17,95 €

CHALECO ACOLCHADO

Bicolor.
Talla: S a 4XL.

G137907
gris/naranja

GOODYEAR



19,95 €

CHALECO REFLECTANTE

Ref.:CHLXLA
Amarillo.
100% poliéster.
Cierre velcro.
Talla XL.

Alta
visibilidad



2,61 €

F-991220

Pantalón
multibolsillos
reforzado
Tallas:
XS-S-M-L-XL-XXL

**CORDURA
FABRIC**



16,95 €

112

CHAQUETA MULTIBOLSILLOS

Tallas S-M-L-XL-XXL.

■ F-991207 CAQUI

■ F-991206 MARINO



6,95 €

PANTALÓN MULTIBOLSILLOS

Tallas XS-S-M-L-XL-XXL.

■ F-991202 CAQUI

■ F-991200 AZULINA



6,95 €



Consulta nuestros catálogos
generales en nuestra web:

www.grupocevik.es

IVA NO INCLUIDO.

La empresa no se hace responsable de
posibles erratas tipográficas o de impresión
en las especificaciones técnicas o en los
precios mostrados en este folleto.

Fecha de validez hasta el
1 de Febrero de 2022

